



Residential Air-to-Water Heat Pump

Service Manual Part 1

Mono Bloc Unit

RAH040

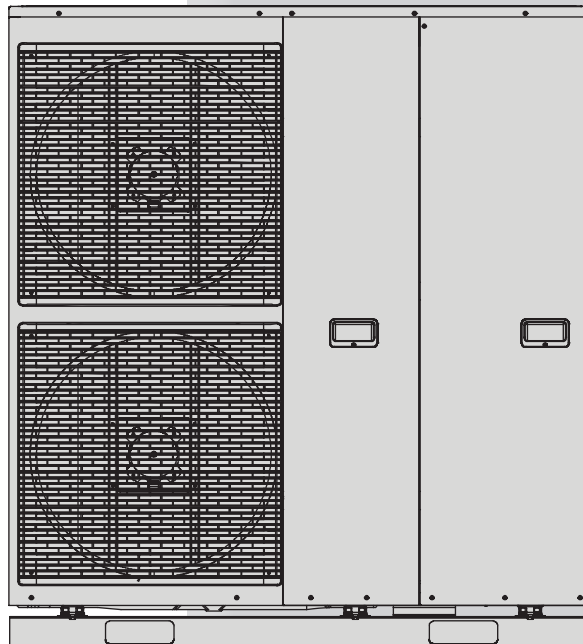

WARNING

This service manual is intended for experienced repair technicians only and is not intended for use by the general public. It does not contain warnings or cautions to advise non-technical individuals of potential dangers in attempting to service a product. Products powered by electricity should be serviced or repaired only by experienced professional technicians. Any attempt to service or repair the products dealt with in this service manual by anyone else could result in serious injury or death.

Save this manual for future reference.

Contents

1. SAFETY PRECAUTIONS	3-5
2. PRECAUTION FOR USING R32 REFRIGERANT	5-12
3. PRODUCT SUMMARY	13-15
4. FEATURES	16
5. LOCATION OF CONTROLS AND COMPONENTS	
Indoor Unit.....	17
Menu Functions Table.....	20-30
6 DIMENSIONS	
Main Components.....	31
Mono Bloc Unit.....	32
7. DIAGRAMS	33-44
8. CIRCUIT BOARDS	45-48
9. INSTALLATION	
Handling the Mono Bloc Unit.....	49
Piping Installation.....	51
Maintenance.....	57
10. INSTALLATION AND SERVICING AIR CONDITIONER USING R32	
About R32 Refrigerant.....	72
Characteristics of R32 Refrigerant.....	72
Refrigerant piping installation • Tools used in service work.....	73-77
New installation, Relocation, Repairing of Refrigerant Cycle System, Procedures.....	78
R32 piping installation.....	79
Installation, Relocation, and Service.....	80
Analysis method for no error code, no cooling / no warming.....	82
*11. Operation and Control	
Basic Function.....	84
Water Pump.....	90
Indoor Unit Safety.....	92
Auto Restart Control.....	92
Indication Panel.....	92
Indoor Backup Heater Control.....	92
Tank Heater Control.....	93
Base Pan Heater Control.....	94
Heater Turn ON/OFF priority Control.....	94
Forced Heating Mode.....	95
Power Mode.....	96
Quiet Mode.....	96
Sterilization Mode.....	96
Outdoor Ambient Thermo OFF Control.....	97
Alternative Outdoor Ambient Sensor Control.....	97
Forced DHW Mode.....	97
SMART DHW Mode.....	97-98
DHW Capacity Setting.....	98
Anti-freeze Control.....	98
Backup Boiler Control.....	99
External Room Thermostat Control (Optional).....	100
Three-way Valve Control.....	100
Two-way Valve Control.....	100
Heat/Cool Switch.....	100
Vacation Mode.....	101
Dry Concrete.....	101
Flow Sensor.....	101
12. PROTECTION CONTROL	
Protection Control for All Operations.....	102
Protection Control for Heating Operation.....	103
13. SERVICE MODE	
Maintenance.....	104
Pump-down Procedures.....	104
How To Adjust Pump Speed.....	105
How to Unlock Cooling Mode.....	106
EEPROM Factory Default Data Setup Procedure.....	107
Dry Concrete Setup.....	108-109
14. MAINTENANCE GUIDE	
Maintenance Menu.....	111
15. TROUBLESHOOTING GUIDE	
Refrigeration Cycle System.....	112
Relationship between the Condition of the Air-to-Water Heat Pump Indoor and Outdoor Units and Pressure and Electric Current.....	113
Breakdown Self-Diagnosis Function.....	113
Error Codes Table.....	115-117
Self-diagnosis Method.....	118-156
16. DISASSEMBLY AND ASSEMBLY INSTRUCTIONS	
To Remove the Cabinet Front Panel.....	157
To Remove the Cabinet Top Plate.....	157
To Remove the Cabinet Back Plate.....	157
To Remove Pressure Gauge.....	157
To Remove Water System Electronic Control Board.....	158
To Remove Air Purge Valve.....	158
To Remove Flow Sensor.....	158
To Remove Water Pump.....	159
To Remove Heater.....	159
To Remove Filter.....	160
17. TECHNICAL DATA	
Operation Characteristics.....	161-164
Heating/Cooling Capacity Tables.....	165
18. EXPLODED VIEW AND REPLACEMENT PARTS LIST	
Water System Exploded View.....	166
Refrigerant System Exploded View.....	167
Outdoor Control Board Exploded View.....	168
Air Flow Exploded View.....	169
Water System Replacement Parts.....	170-171
Refrigerant System Replacement Parts.....	172
Outdoor Control Board Replacement Parts.....	173
Air Flow Replacement Parts.....	174
Revision Notes.....	Back Cover

*Part 1 of the service manual ends here. For information in sections 11-18 refer to Centrus Service Manual Part 2.

1 Safety Precautions

Read the following SAFETY PRECAUTIONS carefully before installing the (Mono bloc) Air-to-Water Heat Pump system (hereafter referred to as “Mono bloc unit”). Electrical work and water installation work must be done by a licensed electrician and a licensed water system installer respectively. Be sure to use the correct rating and main circuit for the model to be installed. The cautions set forth here must be followed because this important information is related to safety. The meaning of each indication used is as follows. Incorrect installation due to ignorance or negligence of the instructions will cause harm or damage; the seriousness of the danger is classified by the following indications.

⚠ WARNING WARNING indicates a potentially hazardous situation which, if not avoided, could result in death or serious injury.

⚠ CAUTION CAUTION indicates the possibility of injury or damage to property only.

















The items to be followed are classified by the symbols:

- ⊘ Symbol with white background denotes item that is PROHIBITED.
- ⚠ Symbol with dark background denotes items that must be carried out.

NOTICE NOTICE indicates special instructions on installation, operation, or maintenance that are important but not related to personal injury or property damage.

⚠ WARNING	
<p>This appliance is not intended for use by persons (including children) with reduced physical, sensory or mental capabilities, or lack of experience and knowledge, unless they have been given supervision or instruction concerning use of the appliance by a person responsible for their safety.</p> <p>Children should be supervised to ensure that they do not play with the appliance.</p>	
Do not use means to accelerate the defrosting process or to clean, other than those recommended by the manufacturer. Any unfit method or use of incompatible material may cause product damage, burst and serious injury.	⊘
Do not install the Mono bloc unit near handrail of balcony. When installing Mono bloc unit on balcony of a high-rise building, children may climb up on Mono bloc unit and cross over the handrail, leading to an accident.	⊘
Do not use unspecified cord, modified cord, joint cord or extension cord for power supply cord. Do not share a single outlet with other electrical appliances. Poor contact, poor insulation, or overcurrent will cause electrical shock or fire.	⊘
Do not tie the power supply cord into a bundle with a band. Abnormal temperature increase may occur in power supply cord.	⊘
Do not insert your fingers or other objects into the unit; high-speed rotating fan may cause injury.	⊘
Do not sit or step on the unit, you may fall accidentally.	⊘
Keep plastic bag (packaging material) away from small children; it may block nose and mouth and cause suffocation.	⊘
Do not purchase unauthorized electrical parts for installation, service, maintenance, etc. They might cause electrical shock or fire.	⊘
Do not pierce or burn as the appliance is pressurized. Do not expose the appliance to heat, flame, sparks, or other sources of ignition. Otherwise, it may explode and cause injury or death.	⊘
This Mono bloc unit is a multi-supply appliance. All circuits must be disconnected before accessing the unit terminals.	⊘
Do not modify the wiring of the Mono bloc unit for installation of other components (i.e., heater, etc). Overloaded wiring or wire connection points may cause electrical shock or fire.	⊘
Do not add or replace refrigerant other than specified type. It may cause product damage, burst, and injury, etc.	⊘
For electrical work, follow national regulations, legislation and these installation instructions. An independent circuit and dedicated outlet must be used. Insufficient electrical circuit capacity or a defect found in the electrical work will cause electric shock or fire.	⚠

1 Safety Precautions

 WARNING	
For water circuit installation work, follow relevant North American and national regulations and local plumbing and building codes.	
Engage a qualified installer, technician or specialist for installation. If installation done by the user is incorrect, it will cause water leakage, electrical shock, or fire.	
Install strictly according to these installation instructions. If installation is defective, it will cause water leakage, electrical shock, or fire.	
Use only the supplied or specified installation parts. Otherwise, the Mono bloc unit may vibrate or fall, or water leakage, electric shock, or fire may occur.	
Install in a flat, strong, and firm location that is able to support the Mono bloc unit's weight. If the location is slanting or insufficiently strong to support the unit, the Mono bloc unit will fall and cause injury.	
Wire routing must be properly arranged so that control board cover is fixed properly. If control board cover is not fixed perfectly, it will cause fire or electrical shock.	
It is strongly recommended that this equipment be installed with a Ground Fault Circuit Interrupter (GFCI) on-site in accordance with the respective national wiring rules or country-specific safety measures regarding residual current.	
The unit is only for use in a closed water system. Using the unit in an open water system may lead to excessive corrosion of the water piping and risk of incubating bacteria colonies, particularly Legionella, in the water.	
If there is any doubt about the installation procedure or operation, always contact a qualified installer or technician for advice and information.	
Select a location where, in case of water leakage, the leakage will not cause damage to other properties.	
When installing electrical equipment in a wooden building that uses metal or wire lath, contact between the building and electrical components is not allowed. This is in accordance with electrical facility standards. An insulator must be installed in between the electrical components and the building.	
This installation may be subject to building code approval applicable to the respective country that may require notifying the local authority before installation.	
Any work carried out on the Mono bloc unit after removing any panel which is secured by screws must be carried out under the supervision of a qualified installer or technician and licensed installation contractor.	
Be aware that refrigerants may not emit an odor.	
This equipment must be properly connected to the ground. Ground wire must not be connected to gas pipe, water pipe, ground of lightning rod, or telephone. Otherwise, it may cause electric shock in case of equipment breakdown or insulation failure.	

FCC Responsible Party:

Lochinvar LLC.
 300 Maddox-Simpson Pkwy, Lebanon, TN 37090
 (800) 722-2101
 lochinvar@lochinvar.com

1 Safety Precautions

CAUTION	
Do not install the Mono bloc unit at a place where leakage of flammable gas may occur. If gas leaks and accumulates in proximity to the Mono bloc unit, it may cause a fire.	
Do not release refrigerant during piping work for installation, re-installation, or during repair of refrigeration parts. Take care with the liquid refrigerant, which may cause frostbite.	
Make sure the insulation of power supply cord does not contact hot components (e.g., refrigerant piping, water piping) to prevent insulation failure (melting of insulation).	
Do not touch the sharp aluminum fin; sharp parts may cause injury.	
Do not apply excessive force to water pipes that may damage the pipes. If water leakage occurs, it will cause flooding and damage to other properties.	
Carry out drainage piping as described in installation instructions. If drainage is not perfect, water leakage may occur and may cause damage to the user's property.	
The piping installation work must be flushed to remove contaminants before the Mono bloc unit is connected. Contaminants may damage the Mono bloc unit components.	
Select an installation location which is easily accessible for maintenance. Incorrect installation, service, or repair of this Mono bloc unit may increase the risk of rupture, which may result in loss of or damage to property and/or injury.	
Ensure the correct polarity is maintained throughout all wiring. Otherwise, it will cause electric shock or fire.	
Power supply connection to Mono bloc unit. <ul style="list-style-type: none"> • Power supply point should be in an easily accessible place for power disconnection in case of emergency. • Local and national wiring standards, regulations, and this installation instruction must be followed. • It is strongly recommended that a permanent connection to a circuit breaker be made. The circuit breaker must be a double pole switch with a minimum 1/8-inch gap. <ul style="list-style-type: none"> - Power supply 1: Use approved 30A circuit breaker - Power supply 2: Use approved 30A circuit breaker 	
After installation, the installer must verify the correct operation of the Mono bloc unit. Check the connection point for water leakage during test run. If leakage occurs, it will cause damage to other properties.	
Keep any required ventilation openings clear of obstruction.	
Installation work. Four or more people are required to carry out the installation work. The weight of the Mono bloc unit may cause injury if carried by fewer than four people.	

Federal Communications Commission Interference Statement

This device complies with part 15 of the FCC Rules. Operation is subject to the following two conditions: (1) This device may not cause harmful interference, and (2) this device must accept any interference received, including interference that may cause undesired operation.

This equipment has been tested and found to comply with the limits for a Class B digital device, pursuant to part 15 of the FCC Rules. These limits are designed to provide reasonable protection against harmful interference in a residential installation. This equipment generates, uses, and can radiate radio frequency energy and, if not installed and used in accordance with the instructions, may cause harmful interference to radio communications. However, there is no guarantee that interference will not occur in a particular installation.

If this equipment does cause harmful interference to radio or television reception, which can be determined by turning the equipment off and on, the user is encouraged to try to correct the interference by one or more of the following measures:

- Reorient or relocate the receiving antenna.
- Increase the separation between the equipment and receiver.
- Connect the equipment to an outlet on a different circuit from the one to which the receiver is connected.
- Consult the dealer or an experienced radio/TV technician for help.













FCC Caution: To ensure continued compliance, follow the attached installation instructions. Any changes or modifications not expressly approved by the party responsible for compliance could void the user's authority to operate the equipment.

Industry Canada Notice

CAN ICES-3(B)/NMB-3(B)

2 Precaution for Using R32 Refrigerant

The basic installation work procedures are the same as for conventional refrigerant (R410A, R22) models. However, pay close attention to the following points:

 WARNING	
<p>Since the working pressure is higher than that of refrigerant R22 models, some of the piping and installation and service tools are special.</p> <p>In particular, when replacing an R22 refrigerant model with a new R32 refrigerant model, always replace the conventional piping with the R32 and R410A piping on the outdoor unit side.</p> <p>The same pipe can be used for R32 and R410A refrigerant.</p>	
<p>The mixing of different refrigerants within a system is prohibited. Models that use R32 and R410A refrigerant have a different charging port thread diameter to prevent erroneous charging with R22 refrigerant and for safety. Therefore, check beforehand. (The charging port thread diameter for R32 and R410A is 1/2 inch.)</p>	
<p>Ensure that no foreign matter (oil, water, etc.) enters the piping.</p>	
<p>Operation, maintenance, repair, and refrigerant recovery should be carried out by trained and personnel certified in the use of flammable refrigerants and as recommended by the manufacturer. Any personnel conducting an operation, servicing, or maintenance on a system or associated parts of the equipment must be trained and certified.</p>	
<p>No part of the refrigeration circuit (evaporators, air coolers, AHU, condensers, or liquid receivers) or piping may be located in proximity to heat sources, open flames, operating gas appliance or an operating electric heater.</p>	
<p>The user/owner or their authorized representative shall regularly check the alarms, mechanical ventilation and detectors, at least once a year, where as required by national regulations, to ensure their correct functioning.</p>	
<p>A logbook must be maintained. The results of these checks must be recorded in the logbook.</p>	
<p>If exhaust vents into occupied spaces, the ventilation ducts must be checked to confirm there is no obstruction.</p>	
<p>Before a new refrigeration system is put into service, the person responsible for placing the system in operation must ensure that trained and certified operating personnel are instructed on the basis of the instruction manual regarding the construction, supervision, operation, and maintenance of the refrigeration system, as well as the safety measures to be observed, and the properties and handling of the refrigerant used.</p>	
<p>The general requirements of trained and certified personnel are indicated below:</p> <ul style="list-style-type: none"> a) Knowledge of legislation, regulations, and standards relating to flammable refrigerants; and b) Detailed knowledge of and skills in handling flammable refrigerants, personal protective equipment, refrigerant leakage prevention, handling of cylinders, charging, leak detection, recovery, and disposal; and c) Ability to understand and apply in practice the requirements of national legislation, regulations, and standards; and d) Ongoing regular and additional training to maintain this expertise. 	
<p>Protect the refrigeration system from accidental rupture due to moving furniture or remodeling activities.</p>	
<p>Refrigerant joints must be tightness tested to ensure no leaks are present. The test method must have a sensitivity of 0.17 ounces per year of refrigerant or better under a pressure of at least 0.25 times the maximum allowable pressure (>151 PSI, max 624 PSI). No leaks must be detected.</p>	

2 Precaution for Using R32 Refrigerant



INSTALLATION (Space)	<ul style="list-style-type: none"> • Must comply with national gas regulations and state and municipal rules and legislation. Notify relevant authorities in accordance with all applicable regulations. • Must ensure mechanical connections are accessible for maintenance purposes. • In cases that require mechanical ventilation, the ventilation openings must be kept clear of obstructions. • When disposing of the product, follow the precautions in the RECOVERY section of this manual and comply with federal regulations. • Always contact local municipal offices for proper handling.
SERVICING	<p>Service personnel</p> <ul style="list-style-type: none"> • Any qualified person who is involved in working on or opening a refrigerant circuit should hold a current, valid certificate from an industry-accredited assessment authority, which verifies their competence to handle refrigerants safely in accordance with an industry-recognized assessment specification. • Servicing may only be performed as recommended by the equipment manufacturer. Maintenance and repair requiring the assistance of other skilled personnel must be carried out under the supervision of the person competent in the use of flammable refrigerants. • Servicing must be performed only as recommended by the manufacturer. • The system must be inspected, regularly supervised, and maintained by trained and certified service personnel who are employed by the responsible person, user, or party. • Ensure refrigerant charge does not leak. <p>Work</p> <ul style="list-style-type: none"> • Prior to beginning work on systems containing flammable refrigerants, safety checks are necessary to ensure that the risk of ignition is minimized. • For repair to the refrigeration system, the precautions in the Servicing section under Work and Checks to Electrical devices must be followed before conducting work on the system. • Work must be undertaken using a controlled procedure to minimize the risk of the presence of flammable gas or vapor while the work is being performed. • All maintenance staff and others working in the local area must be instructed and supervised on the nature of work being carried out. • Avoid working in confined spaces. Always ensure a safety distance of at least 6-1/2 feet from the source, or free space within a radius of at least 6-1/2 feet. • Wear appropriate protective equipment, including respiratory protection, as conditions warrant. • Keep all sources of ignition and hot metal surfaces away. <p>Checking for presence of refrigerant</p> <ul style="list-style-type: none"> • The area must be checked with an appropriate refrigerant detector prior to and during work, to ensure that the technician is aware of a potentially flammable atmosphere. • Ensure that the leak-detection equipment being used is suitable for use with flammable refrigerants, i.e. non-sparking, adequately sealed, or intrinsically safe. • In case of leakage or spillage, immediately ventilate the area and stay upwind and away from the spill/release. • In case of leakage or spillage, notify persons downwind of the leak/spill, isolate the immediate hazard area, and keep unauthorized personnel out. <p>Presence of fire extinguisher</p> <ul style="list-style-type: none"> • Appropriate fire-extinguishing equipment must be available at hand if any hot work is to be conducted on the refrigeration equipment or any associated parts. • Have a dry-powder or CO2 fire extinguisher near the charging area.

2 Precaution for Using R32 Refrigerant

 **CAUTION**

SERVICING

No ignition sources

- No person carrying out work in relation to a refrigeration system which involves exposing any pipework that contains or has contained flammable refrigerant may use any source of ignition in such a manner that it may lead to the risk of fire or explosion. Personnel must not smoke when carrying out such work.
- All possible ignition sources, including lighted cigarettes, must be kept sufficiently far away from the site of installation, repair, removal, and disposal, during which flammable refrigerant may possibly be released into the surrounding space.
- Prior to carrying out work, the area around the equipment must be surveyed to make sure that there are no flammable hazards or ignition risks.
- “No Smoking” signs must be displayed.

Ventilated area

- Ensure that the area is in the open or that it is adequately ventilated before opening the system or conducting any hot work.
- Sufficient ventilation must be ensured during the entire time during which work is being carried out.
- The ventilation must safely disperse any released refrigerant and preferably expel it externally into the atmosphere.

Refrigeration equipment checks

- Where electrical components are being changed, they must be fit for purpose and to the correct specification.
- The manufacturer's maintenance and service guidelines must be followed at all times.
- If in doubt, consult the manufacturer's technical department for assistance.
- The following checks must be applied to installations using flammable refrigerants:
 - The ventilation machinery and outlets must be operating adequately and are not obstructed.
 - Markings on the equipment must remain visible and legible. Markings and signs that are illegible must be corrected.

Checks to electrical devices

- Repair and maintenance to electrical components must include initial safety checks and component inspection procedures.
- Initial safety checks must include but not be limited to:
 - Capacitors must be discharged: This shall be done in a safe manner to avoid the possibility of sparking.
 - No live electrical components and wiring may be exposed while charging, recovering, or purging the system.
 - Continuity of ground bonding must be maintained.
- The manufacturer's maintenance and service guidelines must be followed at all times.
- If in doubt, consult the manufacturer's technical department for assistance.
- If a fault occurs that could compromise safety, then no electrical supply may be connected to the circuit until it is satisfactorily resolved.
- If the fault cannot be corrected immediately but it is necessary to continue operation, an adequate temporary solution must be used.
- The owner of the equipment must be informed or the temporary solution reported so that all parties are advised.

Repairs to sealed components

- Sealed electrical components must be replaced.

2 Precaution for Using R32 Refrigerant

	
REPAIR TO SAFE COMPONENTS	<ul style="list-style-type: none"> • Intrinsically safe components must be replaced.
CABLING	<ul style="list-style-type: none"> • Check that cabling will not be subject to wear, corrosion, excessive pressure, vibration, sharp edges, or any other adverse environmental effects. • The check shall also take into account the effects of aging or continuous vibration from sources such as compressors or fans.
DETECTION OF FLAMMABLE REFRIGERANTS	<ul style="list-style-type: none"> • Under no circumstances may potential sources of ignition be used while searching for or detecting refrigerant leaks. • A halide torch (or any other detector using a naked flame) may not be used.
LEAK DETECTION	<p>The following leak detection methods are considered acceptable for all refrigerant systems:</p> <ul style="list-style-type: none"> • No leaks may be detected when using detection equipment with a sensitivity of 0.17 ounces per year of refrigerant or better under a pressure of at least 0.25 times the maximum allowable pressure (>151 PSI, max 624 PSI) for example, a universal sniffer. • Electronic leak detectors may be used to detect flammable refrigerants, but the sensitivity may not be adequate, or may need recalibration. • (Detection equipment must be calibrated in a refrigerant-free area.) • Ensure that the detector is not a potential source of ignition and is suitable for the refrigerant used. • Leak-detection equipment must be set to a percentage of the LFL of the refrigerant, must be calibrated to the refrigerant used, and the appropriate percentage of gas (25% maximum) must be confirmed. • Leak-detection fluids are also suitable for use with most refrigerants, for example, bubble method and fluorescent method agents. • The use of detergents containing chlorine should be avoided as the chlorine may react with the refrigerant and corrode the copper piping. • If a leak is suspected, all open flames must be removed/extinguished. • If a refrigerant leak is found which requires brazing, all of the refrigerant must be recovered from the system, or isolated (by means of shut-off valves) in a part of the system at a distance from the leak. The precautions in the Removal and Evacuation section of this manual must be followed to remove the refrigerant.

2 Precaution for Using R32 Refrigerant

⚠ CAUTION

REMOVAL AND EVACUATION	<ul style="list-style-type: none"> • When opening the refrigerant circuit to make repairs—or for any other purpose—conventional procedures must be used. However, it is important that best practice is followed since flammability is a consideration. The following procedure must be adhered to: <ol style="list-style-type: none"> 1. Safely remove refrigerant following local and national regulations 2. Evacuate 3. Purge the circuit with inert gas 4. Evacuate 5. Continuously flush with inert gas when using flame to open the circuit 6. Open the circuit • The refrigerant charge must be recovered in the correct recovery cylinders if venting is not allowed by local and national codes. • The system must be purged with OFN to render the appliances safe. (Note: OFN = oxygen-free nitrogen, type of inert gas) • This process may need to be repeated several times. • Compressed air or oxygen must not be used for this task. • Purging must be achieved by breaking the vacuum in the system with OFN and continuing to fill until the working pressure is achieved, then venting to atmosphere, and finally pulling down to a vacuum. • This process must be repeated until no refrigerant remains in the system. • When the final OFN charge is used, the system must be vented down to atmospheric pressure to enable work to take place. • This operation is absolutely vital if brazing operations on the pipework are to take place. • Ensure that the outlet for the vacuum pump is not close to any ignition sources and that ventilation is adequate.
CHARGING PROCEDURES	<ul style="list-style-type: none"> • In addition to conventional charging procedures, the following requirements must be observed: <ul style="list-style-type: none"> - Ensure that contamination of different refrigerants does not occur when using charging equipment. - Hoses or lines must be as short as possible to minimize the amount of refrigerant contained in them. - Cylinders must be kept in an appropriate position in accordance with the instructions. - Ensure that the refrigeration system is grounded prior to charging the system with refrigerant. - Label the system when charging is complete (if not already done). - Extreme care must be taken not to overfill the refrigeration system. • Prior to recharging the system, the system must be pressure tested with OFN (refer to LEAK DETECTION). • The system must be leak tested on completion of charging but prior to commissioning. • A follow-up leak test must be carried out prior to leaving the site. • Electrostatic charge may accumulate and create a hazardous condition when charging and discharging the refrigerant. • To avoid fire or explosion, dissipate static electricity during transfer by grounding and bonding containers and equipment before charging/discharging.

2 Precaution for Using R32 Refrigerant

⚠ CAUTION

DECOMMISSIONING	<ul style="list-style-type: none"> • Before carrying out this procedure, it is essential that the technician be completely familiar with the equipment and all its details. • It is recommended good practice that all refrigerants be recovered safely. • Prior to the task being carried out, an oil and refrigerant sample must be taken in case analysis is required prior to reusing the recovered refrigerant. • It is essential that electrical power be available before the task is started. <ul style="list-style-type: none"> a) Become familiar with the equipment and its operation. b) Isolate system electrically. c) Before attempting the procedure make sure that: <ul style="list-style-type: none"> - mechanical handling equipment is available, if required, for handling refrigerant cylinders; - all personal protective equipment is available and being used correctly; - the recovery process is supervised at all times by a competent person; - recovery equipment and cylinders conform to the appropriate standards. d) Pump down refrigerant system, if possible. e) If a vacuum is not possible, make a manifold so that refrigerant can be removed from various parts of the system. f) Make sure that cylinder is situated on the scale before recovery takes place. g) Start the recovery machine and operate in accordance with manufacturer's instructions. h) Do not overfill cylinders. (No more than 80% volume liquid charge). i) Do not exceed the maximum working pressure of the cylinder, even temporarily. j) When the cylinders have been filled correctly and the process completed, make sure that the cylinders and the equipment are removed from site promptly and all isolation valves on the equipment are closed off. k) Recovered refrigerant may not be charged into another refrigeration system unless it has been cleaned and checked. • Electrostatic charge may accumulate and create a hazardous condition when charging or discharging the refrigerant. • To avoid fire or explosion, dissipate static electricity during transfer by grounding and bonding containers and equipment before charging/discharging.
LABELING	<ul style="list-style-type: none"> • Equipment must be labeled stating that it has been decommissioned and emptied of refrigerant. • The label must be dated and signed. • Ensure that there are labels on the equipment stating the equipment contains flammable refrigerant.

2 Precaution for Using R32 Refrigerant

⚠ CAUTION

RECOVERY

- When removing refrigerant from a system, either for servicing or decommissioning, it is recommended good practice that all refrigerants be removed safely.
- When transferring refrigerant into cylinders, ensure that only appropriate refrigerant recovery cylinders are used.
- Ensure that enough cylinders for holding the total system charge are available.
- All cylinders to be used are designated for the recovered refrigerant and labeled for that refrigerant (i.e., special cylinders for the recovery of refrigerant).
- Cylinders must be complete with pressure-relief valves and associated shut-off valves in good working order.
- Recovery cylinders are evacuated and, if possible, cooled before recovery takes place.
- The recovery equipment must be in good working order with a set of instructions concerning the equipment that is at hand and must be suitable for the recovery of flammable refrigerants. If in doubt, the manufacturer should be consulted.
- In addition, a set of calibrated weighing scales must be available and in good working order.
- Hoses must be complete with leak-free disconnect couplings and must be in good condition.
- The recovered refrigerant must be processed according to local legislation in the correct recovery cylinder, and the relevant waste transfer note arranged. Do not mix refrigerants in recovery units and especially not in cylinders.
- If compressors or compressor oils are to be removed, ensure that they have been evacuated to an acceptable level to make certain that flammable refrigerant does not remain within the lubricant.
- The compressor body must not be heated by an open flame or other ignition sources to accelerate this process. When oil is drained from a system, it must be carried out safely.

3 Product Summary

ITEM	UNIT	REFRIGERANT SYSTEM	
Performance Test Condition		AHRI 550/590	
Cooling Capacity	Condition (Ambient/Water)	A95/W44	
	BTU/h (kW)	34800 (10.2)	
Cooling COP	W/W	2.83	
Heating Capacity	Condition (Ambient/Water)	A47/W105	
	BTU/h (kW)	41000 (12)	
Heating COP	W/W	3.93	
Air Flow	ft ³ /min (m ³ /min)	Cooling: 3620 (102.4) Heating: 2870 (81.3)	
Refrigerant Control Device		Expansion Valve	
Refrigerant Oil (FW50S)	fl oz (cm ³)	40.58 (1200)	
Refrigerant (R32)	lbs (kg)	3.53 (1.60)	
R32	GWP	675	
	CO ₂ eq (ton) (Precharged/Maximum)	1.080 / -	
Compressor	Type		Hermetic Motor
	Motor Type		Brushless (4 poles)
	Rated Output	BTU/h (kW)	10236 (3)
Fan	Type		Propeller Fan
	Material		PP
	Motor Type		DC (8 poles)
	Output Power	W	60
	Fan Speed	RPM	Cooling: Top: 680, Bottom: 720 Heating: Top: 520, Bottom: 560
Fin-Tube Heat Exchanger	Fin Material		Aluminum (Pre Coat)
	Fin Type		Corrugated Fin
	Row x Stage x FPI		2 x 51 x 19
	Size (W x H x L)	inch (mm)	1.5 (38.1) x 49.6 (1259.4) x 35.6 (903.7)

3 Product Summary

ITEM		UNIT	Mono block unit	
Dimension	Height	inch (mm)	55-5/8 (1412.9)	
	Width	inch (mm)	50-5/8 (1285.9)	
	Depth	inch (mm)	12-5/8 (320.7)	
Net Weight		lbs (kg)	317.5 (144)	
Noise Level at a distance of 3.2 ft		Condition (Ambient/Water)	A95/W44	A47/W105
		dB(A)	Cooling: 52	Heating: 52
		Power level dB	Cooling: 69	Heating: 69
Power Source (Phase, Voltage, Cycle)		Ø	Single	
		V	208/240	
		Hz	60	
Input Power		Condition (Ambient/Water)	A95 / W44	A47/W105
		kW	Cooling: 3.6	Heating: 3.05
Maximum Input Power for Heat Pump System		kW	6.54	
Power Supply 1: Phase (Ø) / Max. Current (A) / Max. Input Power (W)			1Ø / 29.0 / 6.54k	
Power Supply 2: Phase (Ø) / Max. Current (A) / Max. Input Power (W)			1Ø / 27.2 / 6.53k	
Starting current		A	15.8	
Running Current		Condition (Ambient/Water)	A95 / W44	A47/W105
		A	Cooling: 18.6 - 16.1	Heating: 15.8 - 13.7
Maximum Current for Heat Pump System		A	29.0	
Power Factor Power factor means total figure of compressor and outdoor fan motor.		Condition (Ambient/Water)	A95 / W44	A47/W105
		%	Cooling: 93	Heating: 93
Thermostat			Electronic Control	
Protection Device			Electronic Control	

3 Product Summary

ITEM		UNIT	Water System
Performance Test Condition			AHRI 550/590
Operation Range	Outdoor Ambient	°F (min. / max.)	Cooling: 50 / 109 Heating: -4 / 95
	Water Outlet	°F (min. / max.)	Cooling: 41 / 68 Heating: 68/131 (Below Ambient -4°F) *2 68/140 (Ambient 41~89.6°F) or Above Ambient 77°F) *3 68/149 (Ambient 41~68°F) *3*4
Internal Pressure Differential		PSI	Cooling: 6 Heating: 8
Water Pipe Diameter	Inlet	inch	1-1/4 NPT
	Outlet	inch	1-1/4 NPT
Water Drain Hose Inside Diameter		inch (mm)	5/8 (15.9)
Pump	Motor Type		DC Motor
	Input Power	W	145
Braze Plate Heat Exchanger	Type		Braze Plate
	No. of Plates		38 or 36
	Size (H x W x L)	inch (mm)	2-7/8 (73) x 4-7/8 (123.9) x 13-1/8 (333.4)
	Water Flow Rate	gal/min (m ³ /h)	Cooling: 9.1 (2.1) Heating: 7.7 (1.8)
Pressure-Relief Valve Water Circuit		PSI	Open: 50, Close: 35 and under
Flow Switch	Type		Electronic Sensor
Protection Device		A	Residual Current Circuit Breaker (40)
Expansion Tank	Volume	G	2.6
	MWP	PSI	14.5
Capacity of Integrated Electric Heater / OLP TEMP		kW / °F	3.33

Note:

- Cooling capacities are based on outdoor air temperature of 95°F Dry Bulb with controlled indoor water inlet temperature of 54°F and water outlet temperature of 44°F.
 - Heating capacities are based on outdoor air temperature of 47°F Dry Bulb, 44.6°F Wet Bulb with controlled indoor water inlet temperature of 95°F and water outlet temperature of 105°F.
 - Specifications are subject to change without prior notice for further improvement.
 - Flow rates indicated are based on nominal capacity adjustment of leaving water temperature (LWT) 105°F and $\Delta 10^\circ\text{F}$.
- *2 Between outdoor ambient 5°F and -4°F, the water outlet temperature gradually decreases from 140°F to 131°F.
 *3 Between outdoor ambient 41°F and 32°F, the water outlet temperature gradually decreases from 149°F to 140°F.
 *3 Between outdoor ambient 68°F and 77°F, the water outlet temperature gradually decreases from 149°F to 140°F.
 *4 Only when ΔT is set to 27°F will the set temperature above 140°F take effect.

4 Features

- **Inverter Technology**
 - Energy saving
- **High Efficiency**
- **Compact Design**
- **Environment Protection**
 - Non-ozone depletion substances refrigerant (R32)
- **Easy-to-use control panel**
- **Weekly Timer**
- **Quality Improvement**
 - Random auto-restart after power failure for safety restart operation
 - Gas leak protection
 - Prevent compressor reverse cycle
 - Inner protector to protect compressor
- **Serviceability Improvement**
 - Breakdown Self Diagnosis function
 - System Status Check Buttons for servicing purposes
 - System Pumpdown Button for servicing purposes
 - Front maintenance design for outdoor unit
- **Operating Condition**

	Heating (Circuit)	Cooling (Circuit)
Water outlet temperature °F (Min / Max)	68 / 131 (Below Ambient -4 °F)*2 68 / 140 (Ambient 41~89.6°F or Above Ambient 77°F)*3 68 / 149 (Ambient 41~68°F)*3*4	41 / 68
Outdoor ambient temperature °F (Min / Max)	-4 / 95	50 / 109

NOTICE: When the outdoor temperature is outside the range in the table, the heating capacity will drop significantly and the mono bloc unit may stop operating to protect itself.

The unit will restart automatically after the outdoor temperature returns to the specified range.

*2 Between outdoor ambient 5°F and -4°F, the water outlet temperature gradually decreases from 140°F to 131°F.

*3 Between outdoor ambient 41°F and 32°F, the water outlet temperature gradually decreases from 149°F to 140°F.

*3 Between outdoor ambient 68°F and 77°F, the water outlet temperature gradually decreases from 149°F to 140°F.

*4 Only when ΔT is set to 27°F will the set temperature above 140°F take effect.

5 Location of Controls and Components

Indoor Unit

Control pad buttons and display

Figure 5-1 Control buttons

Buttons / Indicator	
①	Quick Menu button
②	Back button Returns to the previous screen
③	LCD Display
④	Main Menu button For function setup
⑤	ON/OFF button Starts/Stops operation
⑥	Operation indicator Illuminates during operation, blinks during alarm.

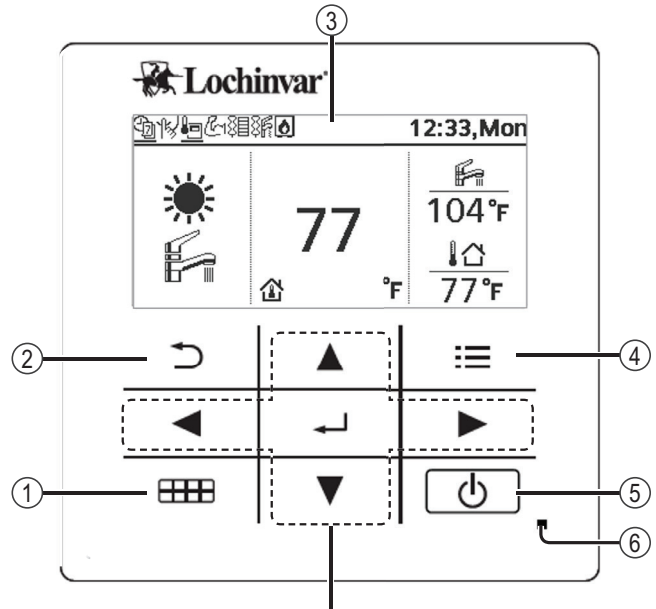

 Press center

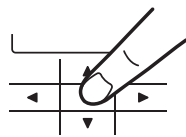

 No glove

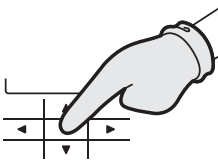

 No pen

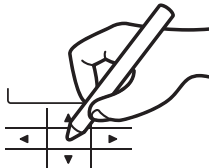

Cross key buttons

Selects an item.

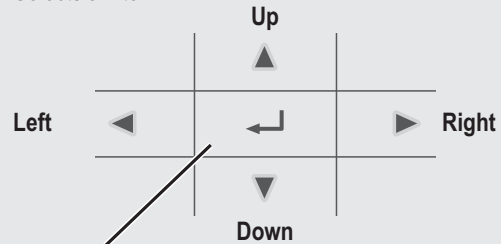

Enter button

Fixes the selected content.

5 Location of Controls and Components

Figure 5-2 Display

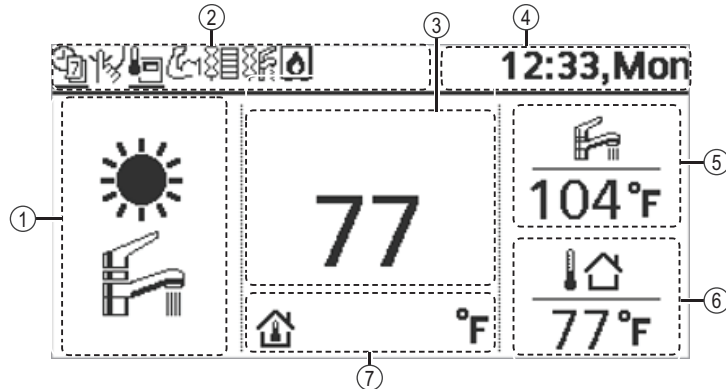

Display

① Mode selection

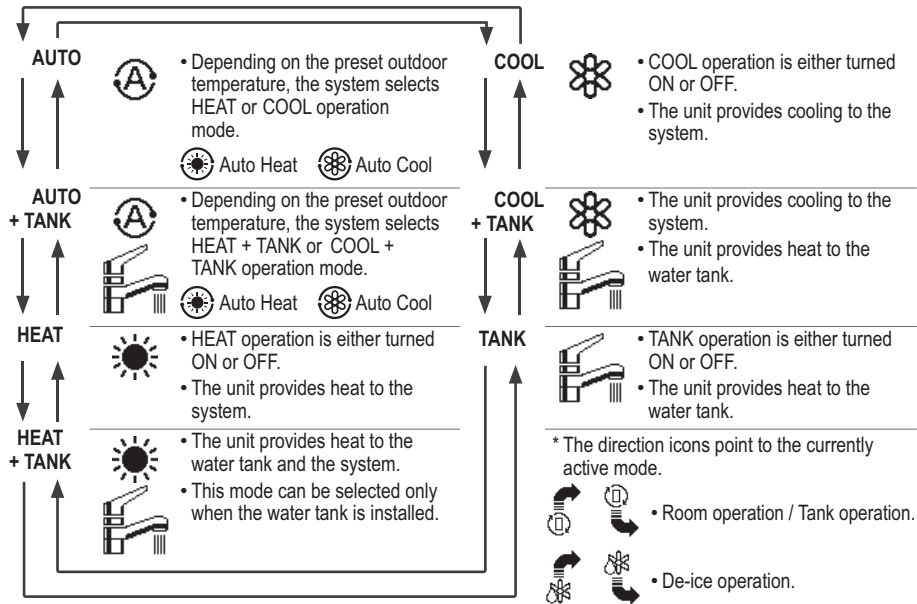

② Operation icons

The status of operation is displayed.

Icon will not display (under operation OFF screen) whenever operation is OFF except weekly timer.

- Holiday operation status (Calendar icon)
- Weekly Timer operation status (Clock icon)
- Quiet operation status (Mute icon)
- Zone:Room Thermostat → Internal sensor status (Thermometer icon)
- Powerful operation status (Lightning bolt icon)
- Room Heater status (Radiator icon)
- Tank Heater status (Tank icon)
- Backup Boiler (Flame icon)

③ Temperature of each zone

④ Time and day

⑤ Water Tank temperature

⑥ Outdoor temperature

⑦ Sensor type/Set temperature type icons

- Water Temperature → Compensation curve (Thermometer with +/- icon)
- Water Temperature → Direct (Thermometer icon)
- Room Thermostat → External (Thermometer with house icon)
- Room Thermostat → Internal (Thermometer with house icon)

5 Location of Controls and Components

Initialization

Before customizing the various menu settings, please initiate the control pad by selecting the desired language of operation and entering the date and time correctly. When power is turned on for the first time, it will display the Settings screen automatically. It can also be set from Personal Settings of the menu.

Figure 5-3 Settings

Selecting the language

Wait while the display is initializing.
When initializing screen ends, it turns to normal screen.
When any button is pressed, language setting screen appears.

- ① Scroll with ▼ and ▲ to select the language.
- ② Press ↵ to confirm the selection.

Setting the clock

- ① Select with ▼ or ▲ how to display the time, either 24h or am/pm format (for example, 15:00 or 3:00 pm).
- ② Press ↵ to confirm the selection.
- ③ Use ▼ and ▲ to select year, month, day, hour and minutes. (Select and move with ▶ and press ↵ to confirm.)
- ④ Once the time is set, time and day will appear on the display even if the Remote Controller is turned OFF.

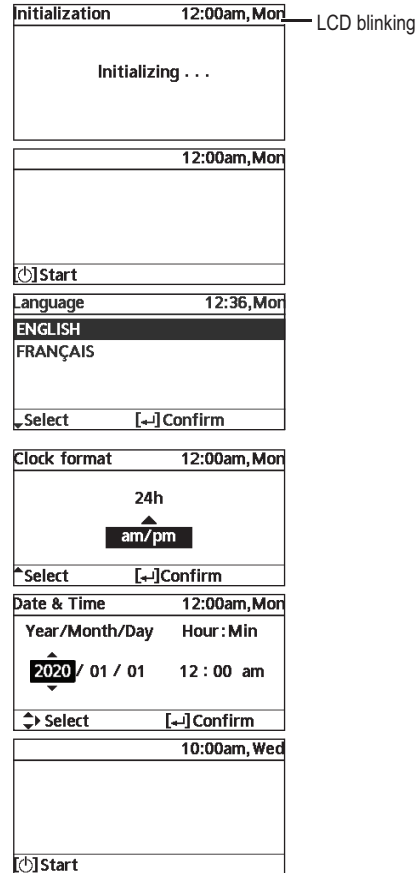

Quick Menu

After the initial settings have been completed, you can select a quick menu from the following options and edit the setting:

Figure 5-4 Quick menu

- ① Press [Grid Icon] to display the quick menu.

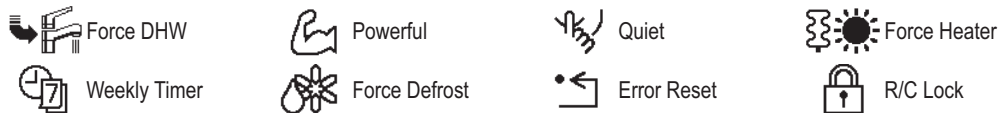
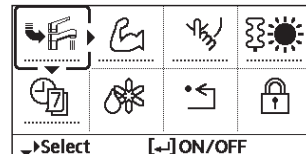

- ② Use ▲ ▼ ◀ ▶ to select menu.
- ③ Press ↵ to turn on/off the select menu.

5 Location of Controls and Components

Menus for User

Select menus and determine settings according to the system available in the household. All initial settings must be made by a qualified installer or service technician. It is recommended that all alterations of the initial settings also be made by an authorized dealer or a specialist.

- After initial installation, you may manually adjust the settings.
- The initial setting remains active until the user changes it.
- The control pad can be used for multiple installations.
- Ensure the operation indicator is OFF before setting.
- The system may not work properly if set incorrectly.

Please consult a qualified installer or service technician.

Figure 5-5 Navigation

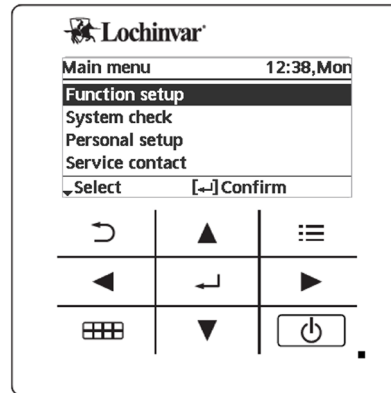

To display <Main Menu>:

To select menu:

To confirm the selected content:

Table 5-1 Menu Functions

Menu Function	Description	Default Setting	Display																												
FUNCTION SETUP	Weekly timer	<p>Timer setup Select day of the week and set the patterns needed. (Time / Operation / ON/OFF / Mode)</p> <p>Timer copy Select the day of the week</p>	<p>Weekly timer 12:42, Mon</p> <table border="1"> <tr> <td>Sun</td> <td>Mon</td> <td>Tue</td> <td>Wed</td> <td>Thu</td> <td>Fri</td> <td>Sat</td> </tr> <tr> <td>1. 8:00</td> <td>ON</td> <td></td> <td></td> <td></td> <td></td> <td>104°F</td> </tr> <tr> <td>2. 12:00</td> <td>ON</td> <td></td> <td></td> <td>77°F</td> <td></td> <td>104°F</td> </tr> <tr> <td>3. 13:00</td> <td>ON</td> <td></td> <td></td> <td>77°F</td> <td></td> <td></td> </tr> </table> <p>↔Day ↘Pattern [↵]Edit</p>	Sun	Mon	Tue	Wed	Thu	Fri	Sat	1. 8:00	ON					104°F	2. 12:00	ON			77°F		104°F	3. 13:00	ON			77°F		
	Sun	Mon	Tue	Wed	Thu	Fri	Sat																								
	1. 8:00	ON					104°F																								
	2. 12:00	ON			77°F		104°F																								
	3. 13:00	ON			77°F																										
Holiday timer	<ul style="list-style-type: none"> • To save energy, a vacation period may be set to either turn the system OFF or lower the temperature during the period. • Weekly timer setting may be temporarily disabled during Holiday timer setting but it will restart once the Holiday timer is completed. 	<p>OFF</p> <p>ON Holiday start and end.</p>	<p><input type="checkbox"/> ON <input checked="" type="checkbox"/> OFF</p> <p>Holiday: End 10:34am, Mon</p> <table border="1"> <tr> <td>Year/Month/Day</td> <td>Hour : Min</td> </tr> <tr> <td>2020 / 01 / 07</td> <td>10 : 00 am</td> </tr> </table> <p>↔Select [↵]Confirm</p>	Year/Month/Day	Hour : Min	2020 / 01 / 07	10 : 00 am																								
Year/Month/Day	Hour : Min																														
2020 / 01 / 07	10 : 00 am																														
Quiet timer	<ul style="list-style-type: none"> • To operate quietly during the preset period. • 6 patterns can be set. • Level 0 means the mode is off. 	<p>Time to Start Quiet Date and time</p> <p>Level of Quietness 0-3</p>	<p>Quiet 10:34am, Mon</p> <table border="1"> <tr> <th>Pattern</th> <th>Time</th> <th>Level</th> </tr> <tr> <td>1</td> <td>8:00 am</td> <td>0</td> </tr> <tr> <td>2</td> <td>5:00 pm</td> <td>1</td> </tr> <tr> <td>3</td> <td>11:00 pm</td> <td>3</td> </tr> </table> <p>↔Select [↵]Edit</p>	Pattern	Time	Level	1	8:00 am	0	2	5:00 pm	1	3	11:00 pm	3																
Pattern	Time	Level																													
1	8:00 am	0																													
2	5:00 pm	1																													
3	11:00 pm	3																													
Room heater	<ul style="list-style-type: none"> • To turn the room heater ON or OFF. 	OFF	<p><input type="checkbox"/> ON <input checked="" type="checkbox"/> OFF</p>																												
Tank heater	<ul style="list-style-type: none"> • To turn the tank heater ON or OFF. • Available only if connected to the tank. 	OFF	<p><input type="checkbox"/> ON <input checked="" type="checkbox"/> OFF</p>																												

5 Location of Controls and Components

Table 5-1 Menu Functions continued

Menu Function		Description	Default Setting	Display
FUNCTION SETUP	Sterilization	<ul style="list-style-type: none"> To set the auto sterilization ON or OFF. Available only if connected to the tank. Do not use the system during sterilization in order to prevent scalding with hot water or overheating of shower. Ask a qualified installer or service technician to determine the level of sterilization function field settings according to local laws and regulations. 	OFF	
SYSTEM CHECK	Energy monitor	<ul style="list-style-type: none"> Present or historical chart of energy consumption, generation, or COP (Coefficient of Performance). For historical chart, the period is selected from 1 day/1 week/1 year. Energy consumption (kWh) of heating, cooling, tank, and total may be retrieved. The total power consumption is an estimated value based on 240 VAC and may differ from value measured by precise equipment. 	Present Select and retrieve Historical Chart Select and retrieve	
	System information	<ul style="list-style-type: none"> Shows all system information in each area. 	Actual system information for 10 items: Inlet / Outlet / Tank / Buffer tank / COMP frequency / Pump flow rate Select and retrieve	
	Error history	<ul style="list-style-type: none"> Refer to Troubleshooting for error codes. The most recent error code is displayed at the top. 	Select and retrieve	
	Compressor	<ul style="list-style-type: none"> Shows the compressor performance. 	Select and retrieve	
	Heater	<ul style="list-style-type: none"> Total hours of ON time for Room heater/ Tank heater. 	Select and retrieve	

5 Location of Controls and Components

Table 5-1 Menu Functions continued

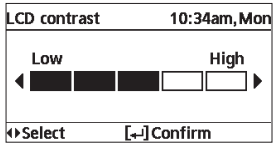
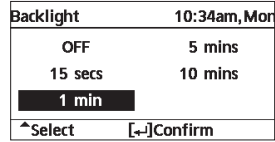
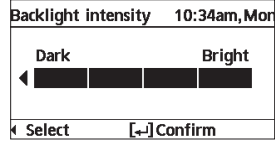
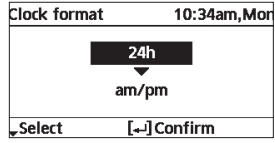
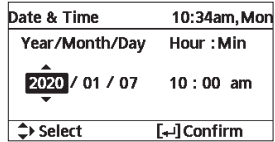
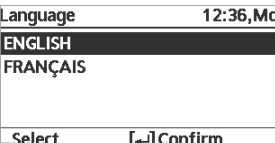
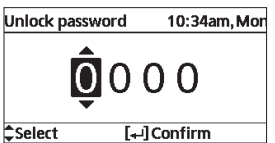
Menu Function	Description	Default Setting	Display	
PERSONAL SETUP	Touch sound	•Turns the operation sound ON/ OFF.	ON	
	LCD contrast	•Sets the screen contrast.	3	
	Backlight	•Sets the duration of screen backlight.	1 min	
	Backlight intensity	•Sets screen backlight brightness.	4	
	Clock format	•Sets the type of clock display.	24h	
	Date & Time	•Sets the current date and time.	Year / Month / Day / Hour / Min	
	Language	•Sets the display language for the top screen.	ENGLISH / FRANCAIS	
	Unlock password	•4-digit password for all settings.	0000	

5 Location of Controls and Components

Table 5-1 Menu Functions continued

Menu Function	Description	Default Setting	Display	
INSTALLER SETUP > SYSTEM SETUP	Service Contact 1 / Contact 2	•Preset contact number for installer	OFF	
	Heater capacity	•To reduce the heater power if unnecessary.	6 kW	
	Anti-freeze	•To activate or deactivate the water freeze prevention when the system is OFF	Yes	
	Tank connection	•To connect tank to the system.	No	
	DHW capacity	•To set tank heating capacity to variable or standard. Variable capacity heat-up tank with fast mode; maintains the tank temperature with Efficient Mode. •Standard capacity heat-up tank with rated heating capacity. This option is available if Tank connection is selected (YES).	Variable	
	Buffer tank connection	•To connect tank to the system and if selected YES, to set ΔT temperature.	No	
			9°F	
Tank heater	•To select external or internal tank heater, and if External is selected, set a timer for the heater to turn on. This option is available if Tank connection is selected (YES).	Internal		
		0:20		

5 Location of Controls and Components

Table 5-1 Menu Functions continued

Menu Function	Description	Default Setting	Display	
INSTALLER SETUP > SYSTEM SETUP	Base pan heater	<ul style="list-style-type: none"> Type A - The base pan heater activates only during defrost operation. Type B - The base pan heater activates when outdoor ambient temperature is 41°F or lower. 	A	Base pan heater type 10:34am, Mon A ▼ B Select [←] Confirm
	Alternative outdoor sensor	<ul style="list-style-type: none"> To select an alternative outdoor sensor. 	No	Yes ▲ No
	Backup boiler	<ul style="list-style-type: none"> To enable or disable backup boiler. 	No	Yes ▲ No
	Circulation liquid	<ul style="list-style-type: none"> To select whether to circulate water or glycol mixture in the system. 	Water	Circulation liquid 10:34am, Mon Water ▼ Glycol Select [←] Confirm
	Heat-Cool SW		No	Yes ▲ No
	Forced heating	<ul style="list-style-type: none"> To turn on forced heating either manually (by default) or automatically. 	Manual	Force heater 10:34am, Mon Auto ▲ Manual Select [←] Confirm
	Force defrost	<ul style="list-style-type: none"> If auto-selection is set, the unit will start defrost operation if heating operates for long periods when the outdoor temperature is cold. 	Manual	Auto ▲ Manual
	Defrost signal	<ul style="list-style-type: none"> To turn on defrost signal to stop fan coil during defrost operation. If Defrost signal is set to Yes, Backup boiler function will not be available. 	No	Yes ▲ No
	Pump flow rate	<ul style="list-style-type: none"> To set variable flow pump control or fixed pump duty control. 	ΔT	ΔT ▼ Max. Duty

5 Location of Controls and Components

Table 5-1 Menu Functions continued

Menu Function	Description	Default Setting	Display
INSTALLER SETUP > OPERATION SETUP	Operation Setup	•To access the four major functions or modes.	Heat / Cool / Auto / Tank
	Heat	•To set various water and ambient temperatures for heating.	Heat / Cool / Auto / Tank
			Water temp. for heating ON / Outdoor temp. for heating OFF / ΔT for heating ON / Heater ON/OFF
			Water temp. at which heating turns ON Compensation curve Heating ON temps in compensation curve or direct input
			Compensation Curve X axis: 23°F, 59°F Y axis: 131°F, 95°F Input the 4 temperature points (2 on horizontal X axis, 2 on vertical Y axis).
			•Temperature range: X axis: -4°F ~ 59°F, Y axis: See below. •Temperature range for the Y axis input: 1. RAH040 model: 68°F ~ 149°F •Regardless of the above setting, there is a limit to the water set temperature.
			Water temp. for heating ON > Direct 95°F
		Temperature for heating ON	
		Min. ~ Max. range is conditional as follows: RAH040 model: 68°F ~ 149°F Regardless of the above setting, there is a limit to the water set temperature.	

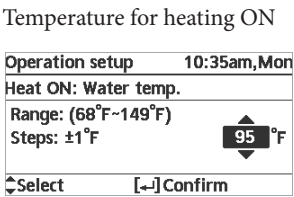
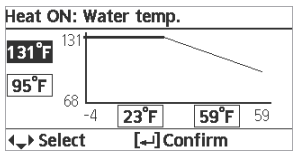
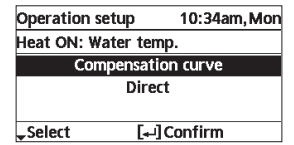
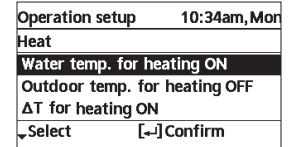
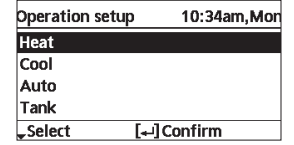

5 Location of Controls and Components

Table 5-1 Menu Functions continued

Menu Function	Description	Default Setting	Display		
INSTALLER SETUP > OPERATION SETUP	Heat	<ul style="list-style-type: none"> To set various water and ambient temperatures for heating. 	Temperature for heating OFF Operation setup 12:50, Mon Heat OFF: Outdoor temp. Range: (41°F~95°F) Steps: ±1°F 75 °F Select [-] Confirm		
			ΔT for heating ON 9°F Set ΔT for heating ON. * This setting will not be available to set when pump flow rate is set to Max. duty. Operation setup 12:51, Mon Heat ON: ΔT Range: (2°F~27°F) Steps: ±1°F 9 °F Select [-] Confirm		
			Heater ON/OFF		
			Heater ON/OFF> Outdoor temp. for heater ON 32°F Temperature for heater ON Operation setup 12:51, Mon Heater ON: Outdoor temp. Range: (-4°F~59°F) Steps: ±1°F 32 °F Select [-] Confirm		
			Heater ON/OFF > Delay time for heater ON 0:30 min Delay time for heater to turn on Operation setup 10:34am, Mon Heater ON: Delay time Range: (0:10~1:00) Steps: ±0:10 0:30 Select [-] Confirm		
			Heater ON/OFF > Water temperature for heater ON -7°F Setting of water temperature to turn on from water set temperature. Operation setup 12:53, Mon Heater ON: ΔT of target Temp. Range: (-18°F~-4°F) Steps: ±1°F -7 °F Select [-] Confirm		
			Heater ON/OFF > Water temperature for heater OFF -4°F Setting of water temperature to turn off from water set temperature. Operation setup 12:53, Mon Heater OFF: ΔT of target Temp. Range: (-6°F~0°F) Steps: ±1°F -4 °F Select [-] Confirm		

5 Location of Controls and Components

Table 5-1 Menu Functions continued

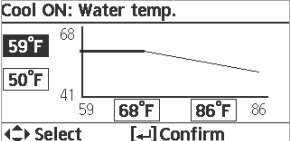
Menu Function		Description	Default Setting	Display
INSTALLER SETUP > OPERATION SETUP	Cool	<ul style="list-style-type: none"> To set various water & ambient temperatures for cooling. 	Water temperatures for cooling ON and ΔT for cooling ON.	Operation setup 10:34am, Mon Cool Water temp. for cooling ON ΔT for cooling ON Select [←] Confirm
			Water temp. for cooling ON Cooling ON temperatures in compensation curve or direct input.	Operation setup 10:34am, Mon Cool ON: Water temp. Compensation curve Direct Select [←] Confirm
			Water temp. for cooling ON > Compensation Curve X axis: 68°F, 86°F Y axis: 59°F, 50°F Input the 4 temperature points (2 on horizontal X axis, 2 on vertical Y axis)	Cool ON: Water temp.  Select [←] Confirm
			Water temp. for cooling ON > Direct 50°F Set temperature for Cooling ON	Operation setup 12:55, Mon Cool ON: Water temp. Range: (41°F~68°F) Steps: ±1°F 50 °F Select [←] Confirm
			ΔT for cooling ON 9°F Set ΔT for cooling ON * This setting will not be available when pump flow rate is set to Max. duty.	Operation setup 12:56, Mon Cool ON: ΔT Range: (2°F~27°F) Steps: ±1°F 9 °F Select [←] Confirm

5 Location of Controls and Components

Table 5-1 Menu Functions continued

Menu Function		Description	Default Setting	Display
INSTALLER SETUP > OPERATION SETUP	Auto	<ul style="list-style-type: none"> Automatically switch from Heat to Cool or Cool to Heat. 	Outdoor temperatures for switching from Heat to Cool or Cool to Heat. Outdoor temp. for (Heat to Cool) / Outdoor temp. for (Cool to Heat)	
			Outdoor temp. for (Heat to Cool) 59°F Set outdoor temperature for switching from Heat to Cool.	
			Outdoor temp. for (Cool to Heat) 50°F Set outdoor temperature for switching from Cool to Heat.	
	Tank	<ul style="list-style-type: none"> Setting functions for the tank. Available only if connected to the tank. 	Floor operating time (max) / Tank heat-up time (max) / Tank reheat temp. / Sterilization The display will show 3 functions at a time.	
			Floor operation time (max) 8:00 Maximum time for floor operation (in hours and minutes)	
			Tank heating time (max) 1:00 Maximum time for heating the tank (in hours and minutes)	
			Tank reheat temp. -14°F Set temperature to initiate reheating of tank water.	
			Sterilization Monday Sterilization may be set for 1 or more days of the week. Sun / Mon / Tue / Wed / Thu / Fri / Sat	

5 Location of Controls and Components

Table 5-1 Menu Functions continued

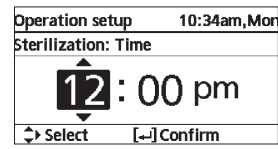
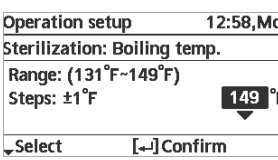
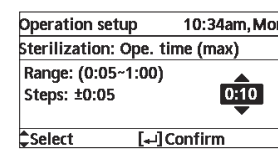
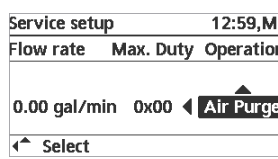
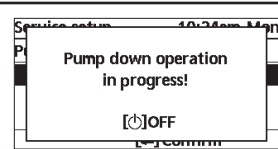
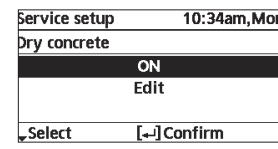
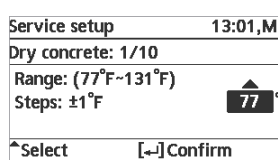
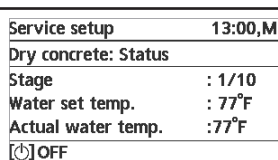
Menu Function		Description	Default Setting	Display
INSTALLER SETUP > OPERATION SETUP	Tank	<ul style="list-style-type: none"> Automatically switch from Heat to Cool or Cool to Heat. 	Sterilization: Time 12:00 Time on selected day(s) of the week to sterilize the tank 0:00 ~ 23:59	
			Sterilization: Boiling Temp 149°F Set boiling temperatures to sterilize the tank.	
			Sterilization: Oper. time (max) 0:10 Set sterilizing time (in hours and minutes)	
INSTALLER SETUP > SERVICE SETUP	Pump maximum speed	<ul style="list-style-type: none"> To set the maximum speed of the pump. 	Setting the flow rate, max. duty and operation ON/OFF of the pump. Flow rate: XX.X gal/min Max. Duty: 0x40 ~ 0xFE, Pump: ON / OFF / Air Purge	
	Pump down	<ul style="list-style-type: none"> To set the pump down operation. 	Pump down operation ON	
	Dry Concrete	<ul style="list-style-type: none"> To dry concrete (floor, walls, etc.) during construction. Do not use this menu for any other purposes or at any other time other than during construction. 	Edit to set the temperature of dry concrete. ON / Edit	
Edit Stages: 1 Temperature: 77°F Heating temperature for drying concrete. Select the desired stages: 1 ~ 10, range: 1 ~ 99				
ON Confirm the temperatures of dry concrete for each stage.				

5 Location of Controls and Components

Table 5-1 Menu Functions continued

Menu Function		Description	Default Setting	Display
INSTALLER SETUP > SERVICE SETUP	Service contact	<ul style="list-style-type: none"> To set up to 2 contact names and numbers for the user. 	Service engineer's name and contact number. Contact 1 / Contact 2	<pre>Service setup 10:34am, Mon Service contact: Contact 1 Contact 2 Select [←] Confirm</pre>
			Contact 1 / Contact 2 Contact name or number. Name / phone icon	<pre>Service contact 10:34am, Mon Contact 1 Name : Bryan Adams Phone : 08812345678 Select [←] Edit</pre>
			Input name and number Contact name: alphabet a ~ z. Phone number: 1 ~ 9	<pre>Contact-1 ABC/abc 0-9/Other ABCDEFGHIJ KLMNOPQR Space STUVWXYZ abcdefghi BS jklmnopqrstuvwxyz Conf Select [←] Enter Number: 1 2 3 (4 5 6) 7 8 9 - BS * 0 # _ Conf Select [←] Enter</pre>

5 Location of Controls and Components

Main Components

- 1. Printed Circuit Board**
Used to control unit function
- 2. Single-phase Residual Current Circuit Breaker**
Used to protect electrical components.
- 3. Heat exchanger**
A brazed plate heat exchanger used to transfer energy between refrigerant and the liquid medium used in the system.
- 4. Water pressure gauge**
Used to measure the internal water pressure of the unit.
- 5. Water pump**
A pump used to circulate the liquid medium through the unit.
- 6. Cabinet top plate**
The top cover of the unit.
- 7. Expansion tank**
A component used to compensate for pressure fluctuations in the liquid piping.
- 8. Flow sensor**
A component used to measure the flow rate of the liquid medium moving through the unit.
- 9. Heater assembly**
An assembly consisting of two 3kW heating elements.
- 10. Overload protector**
OLP is used to protect the heating elements and electrical components from abnormal power consumption.
- 11. Pressure relief valve**
Used to relieve pressure in the water system when the system's maximum pressure is exceeded.
- 12. Air purge valve**
Used to eliminate any air pockets in the pressurized water system. Ensures proper fluid flow through the unit.
- 13. Water filter set**
A magnetic filter used to protect the water system from harmful particulates.
- 14. Plug (2 pieces)**
Used to keep unwanted particulates out of water piping during shipping.
- 15. Bushing (6 pieces)**
Used to help ensure wires protruding from the unit PCB are not cut by sheet metal.
- 16. Cabinet front panel**
The front cover of the unit.
- 17. Cover**
The service port cover of the water system.
- 18. Water inlet**
The port where water is fed into the unit.
- 19. Water outlet**
The port where water is expelled from the unit.

It is advisable to avoid more than 2 blockage directions. For better ventilation & multiple-outdoor installation, please consult a qualified installer or service technician.

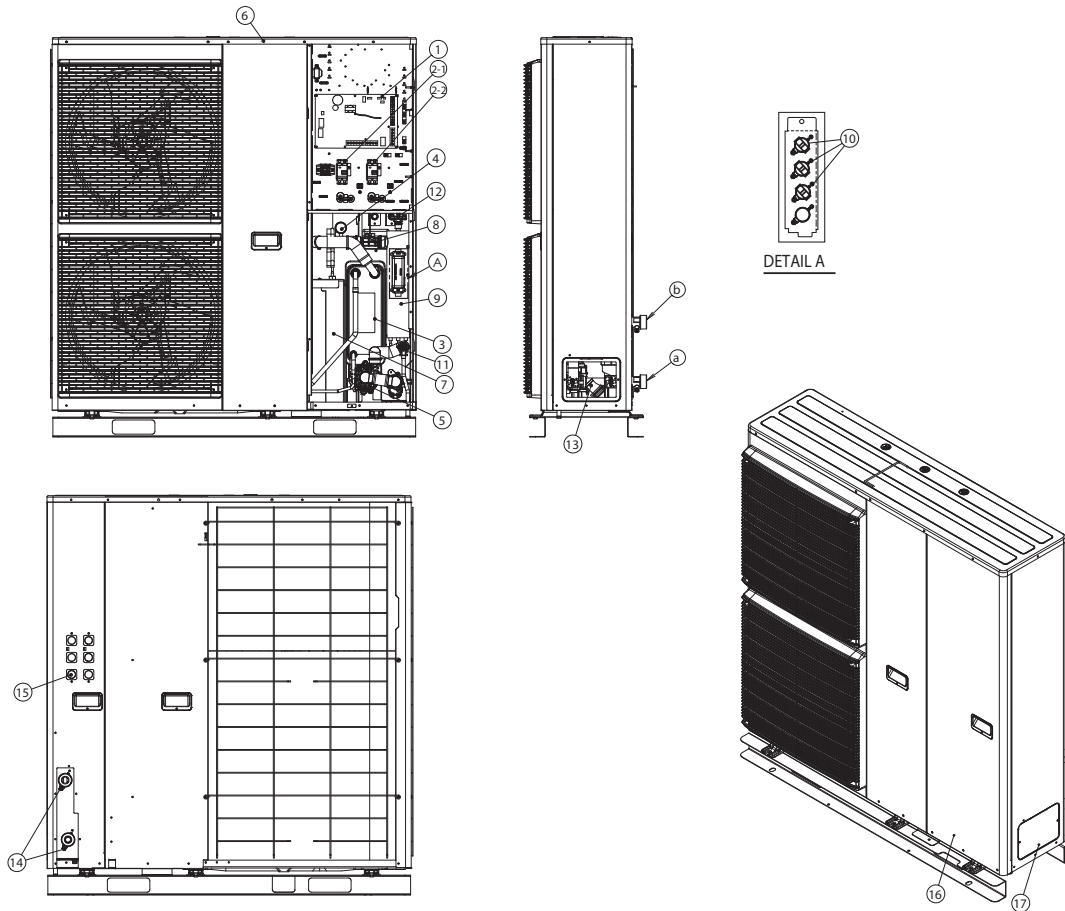

6 Dimensions

Figure 6-1 Unit Dimensions - Front & back view

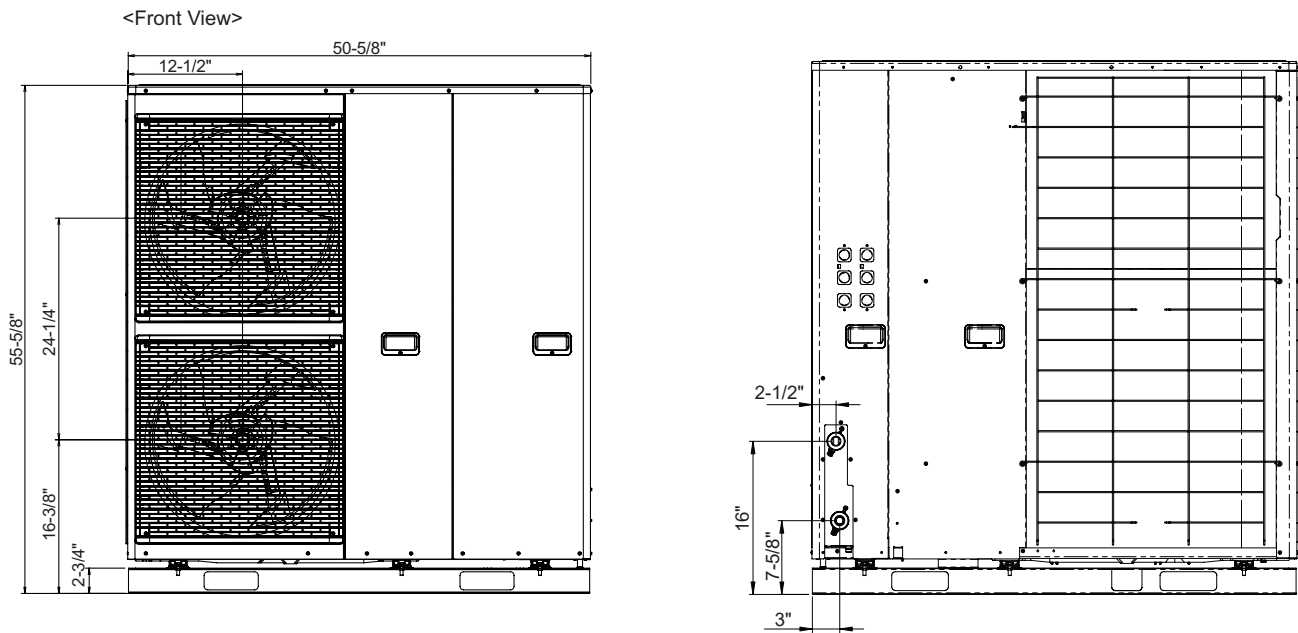
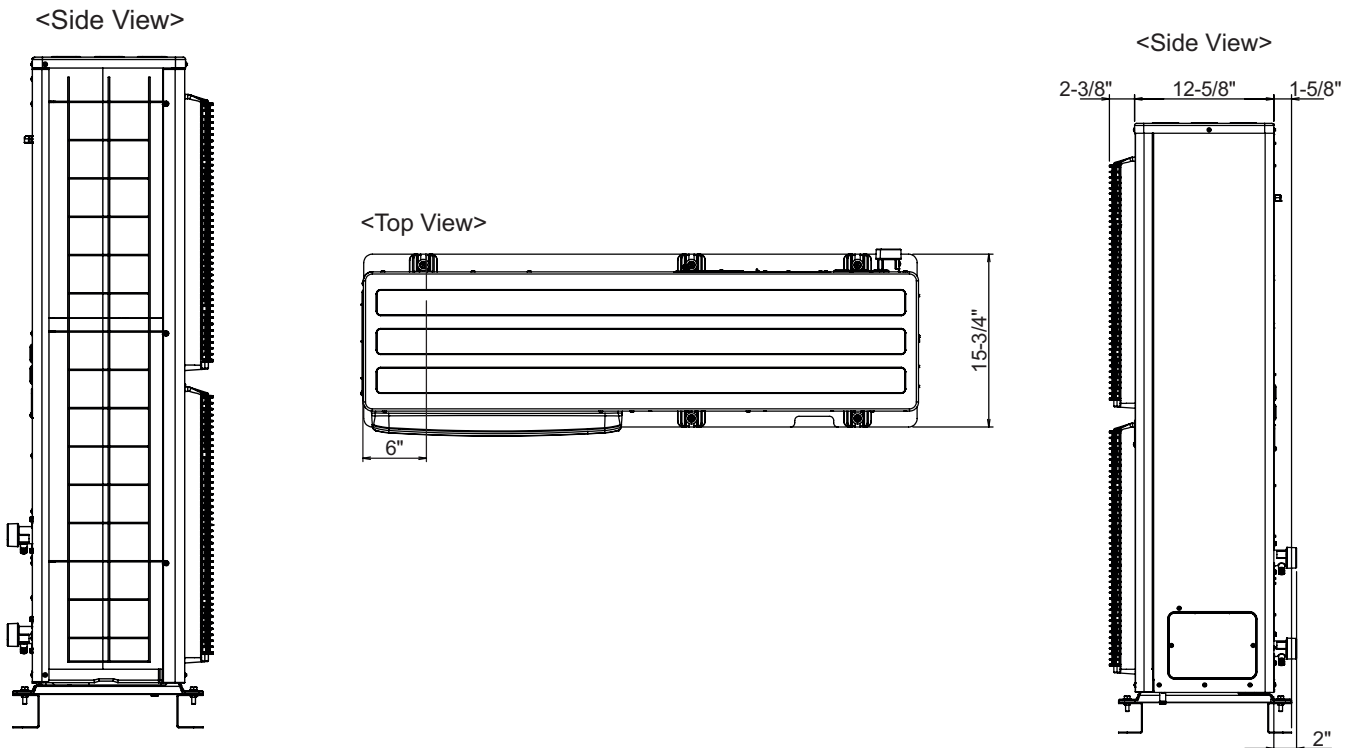
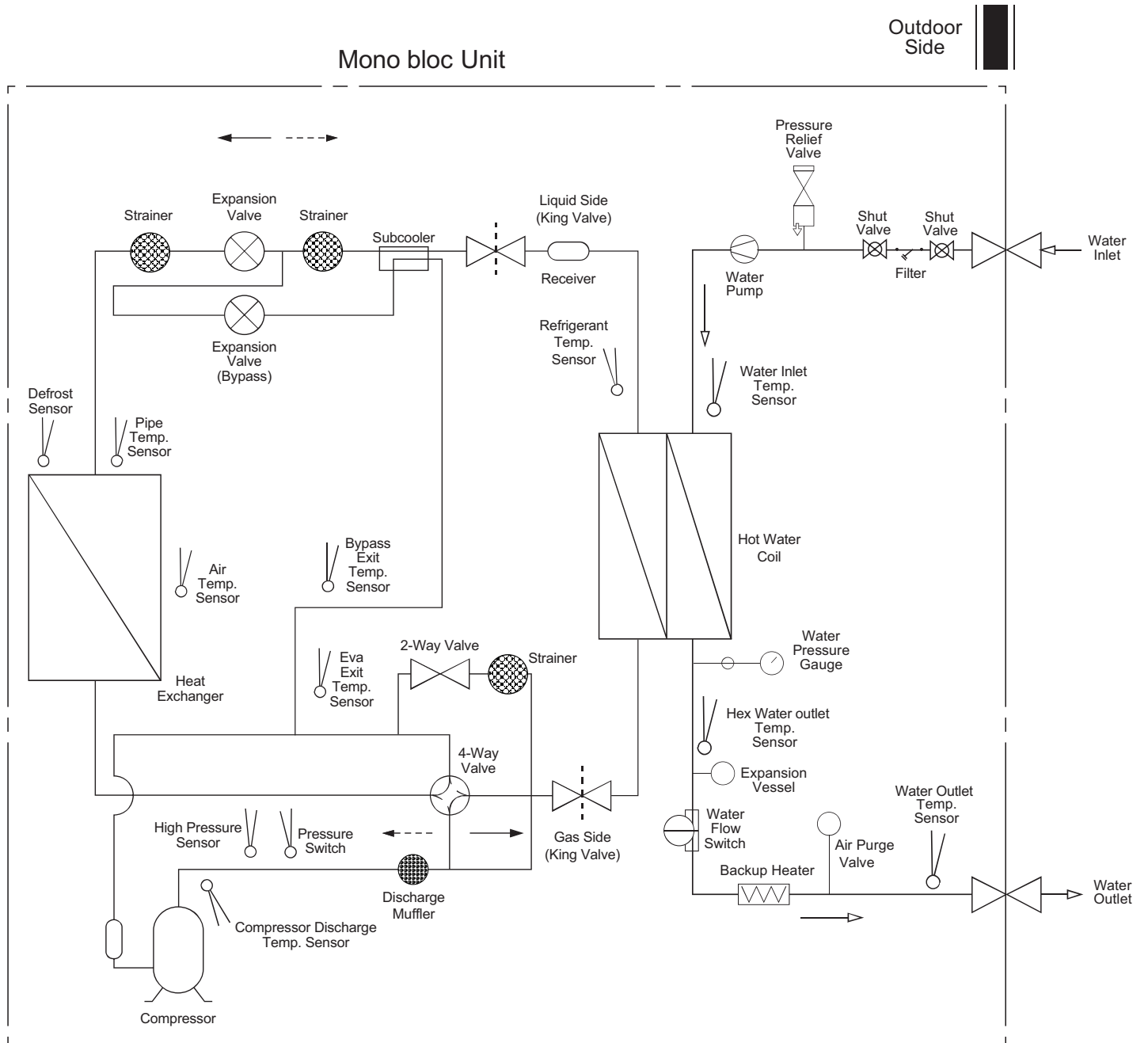

Figure 6-2 Unit Dimensions - Side & top view



7 Diagrams

Figure 7-1 Refrigeration and Water Cycle Diagram



- ▶ Refrigerant Cycle (Heating)
- ▶ Water Cycle
- - -▶ Refrigerant Cycle (Cooling)

7 Diagrams

Figure 7-2 Refrigeration and Water Cycle Diagram - Heating Loop

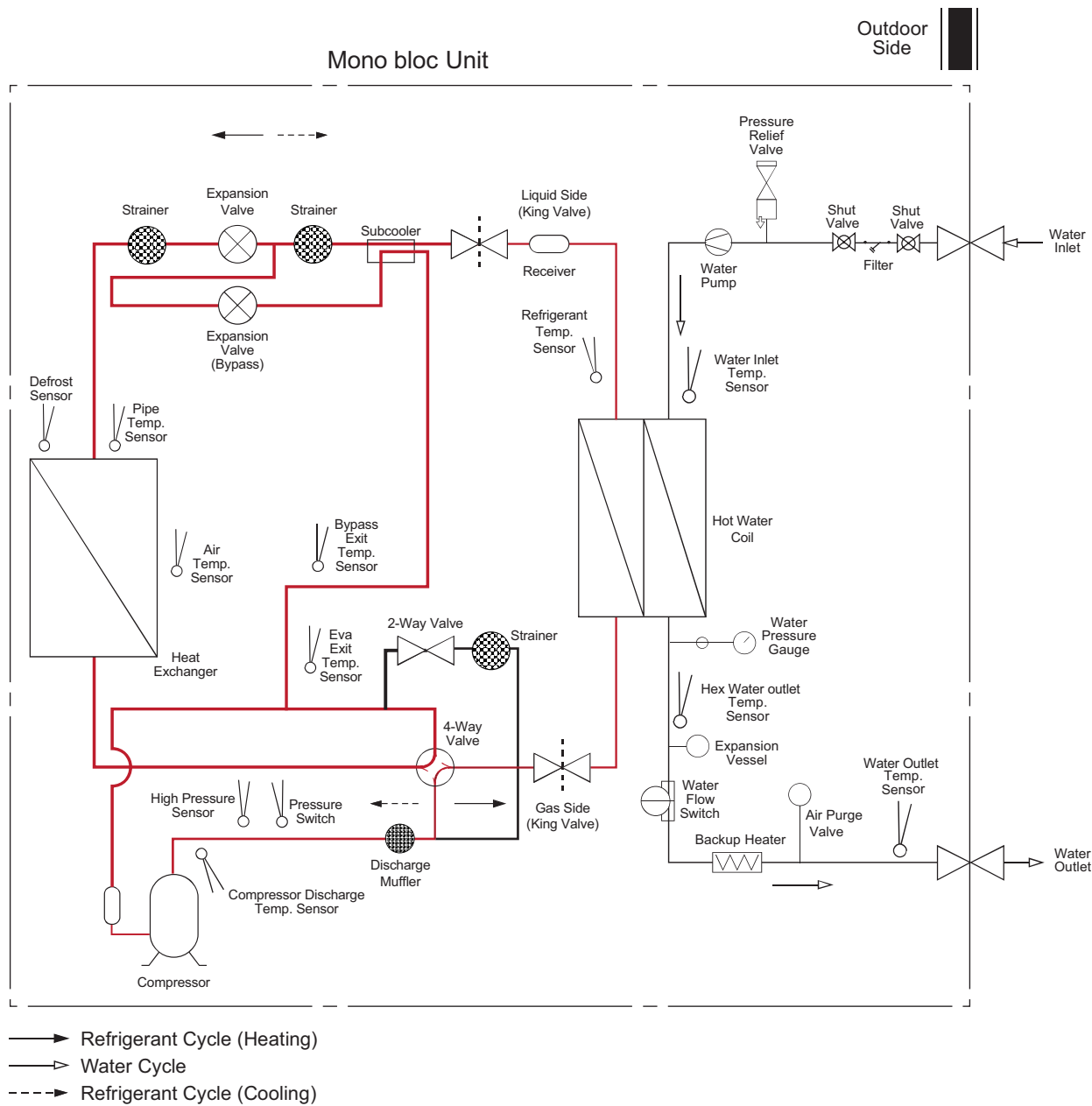

7 Diagrams

Figure 7-3 Refrigeration and Water Cycle Diagram - Cooling Loop

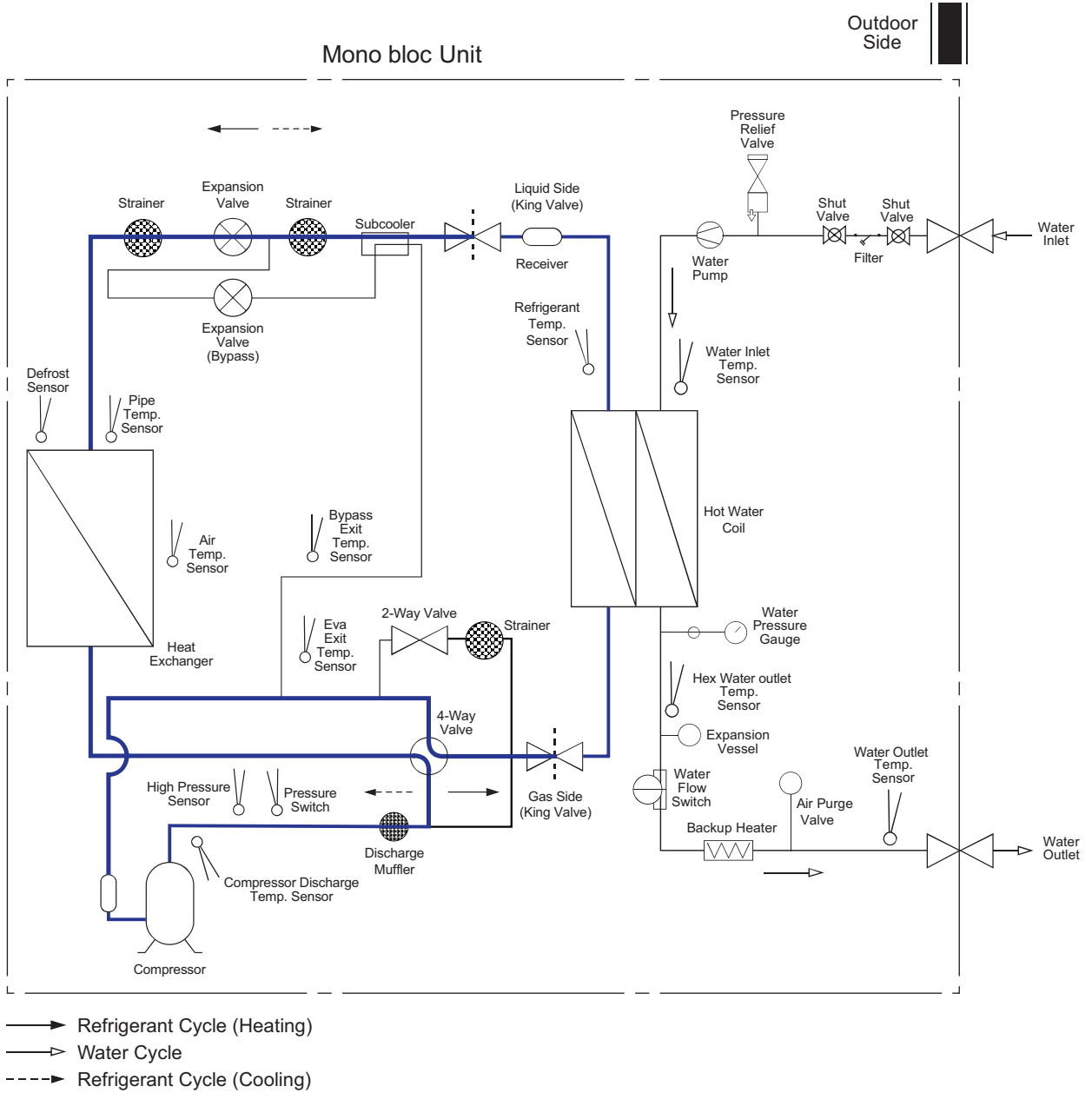

7 Diagrams

Figure 7-4 Optional Piping System

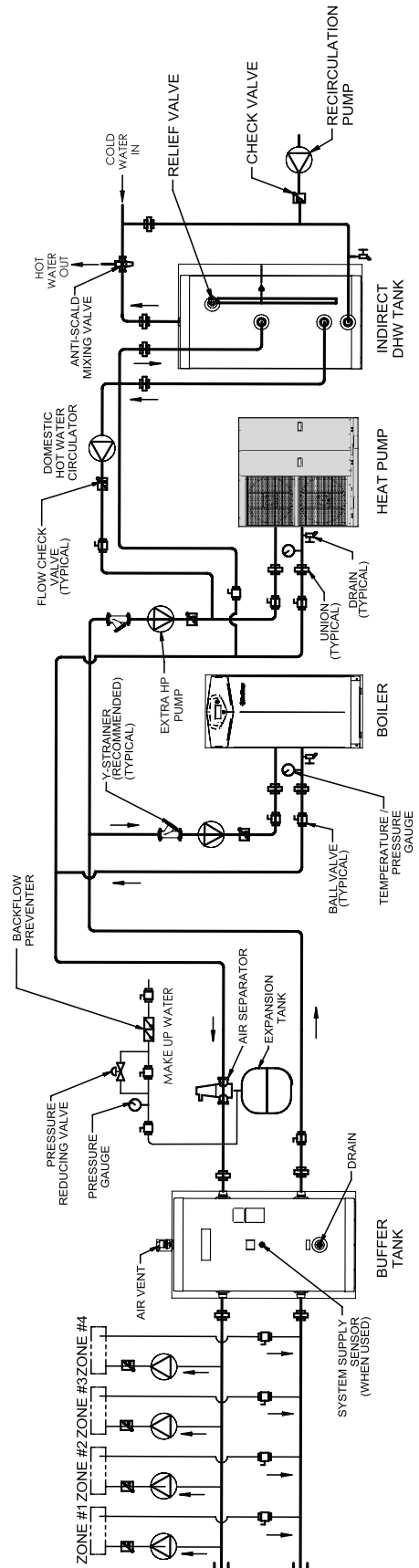

2000845882 00

7 Diagrams

Figure 7-5 Indirect Tank Piping System

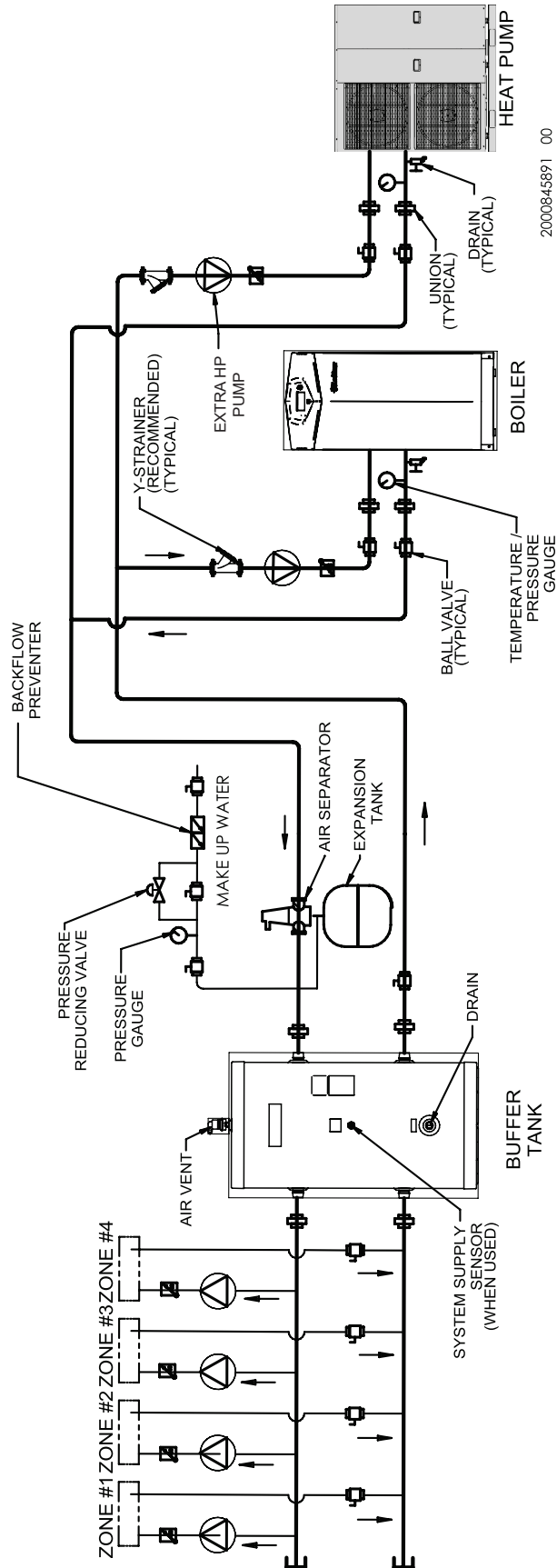

7 Diagrams

Figure 7-6 No Boiler, No Indirect Tank Piping System

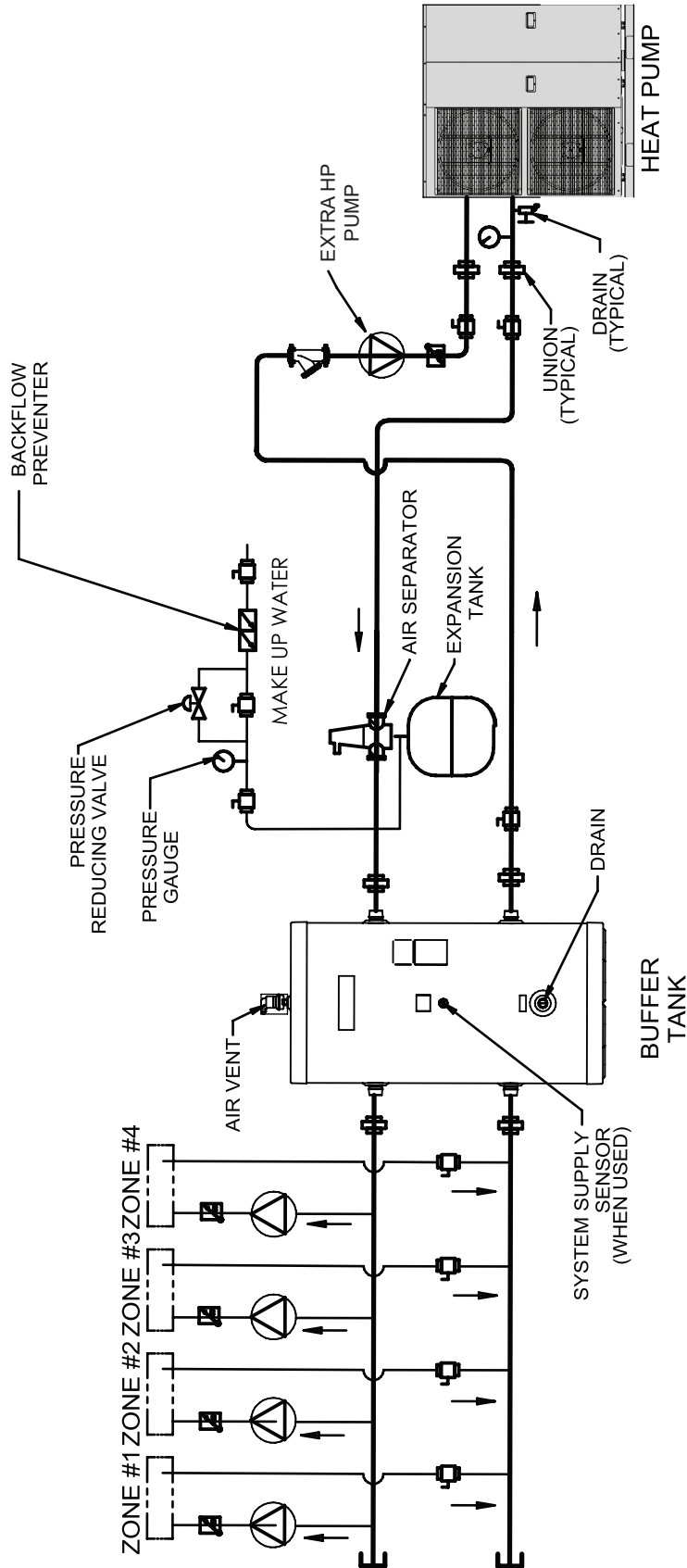

2000845896 00

7 Diagrams

Figure 7-7 Indirect DHW Piping System

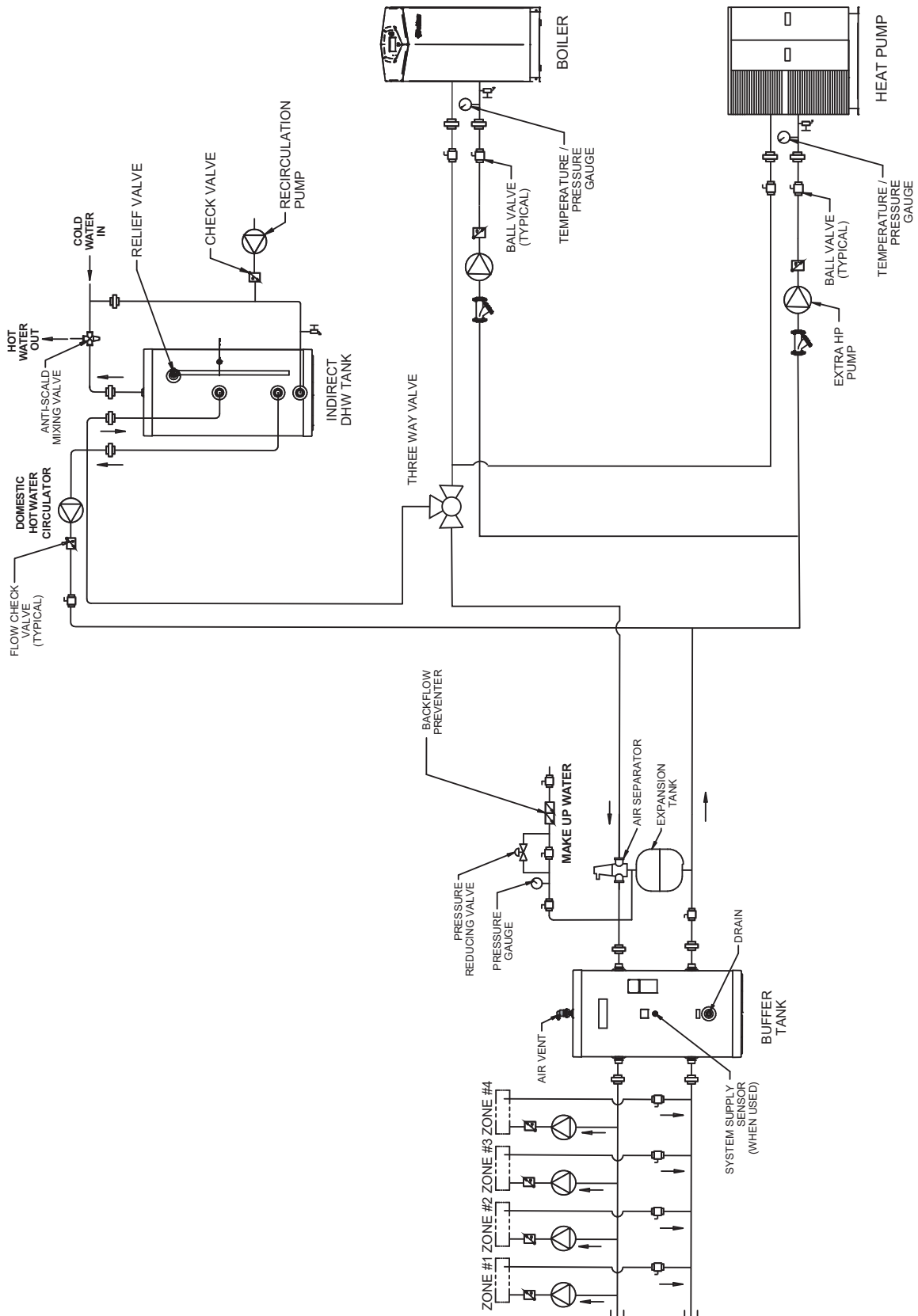

DIR 2000856414 REV A

7 Diagrams

Figure 7-8 Block Diagram

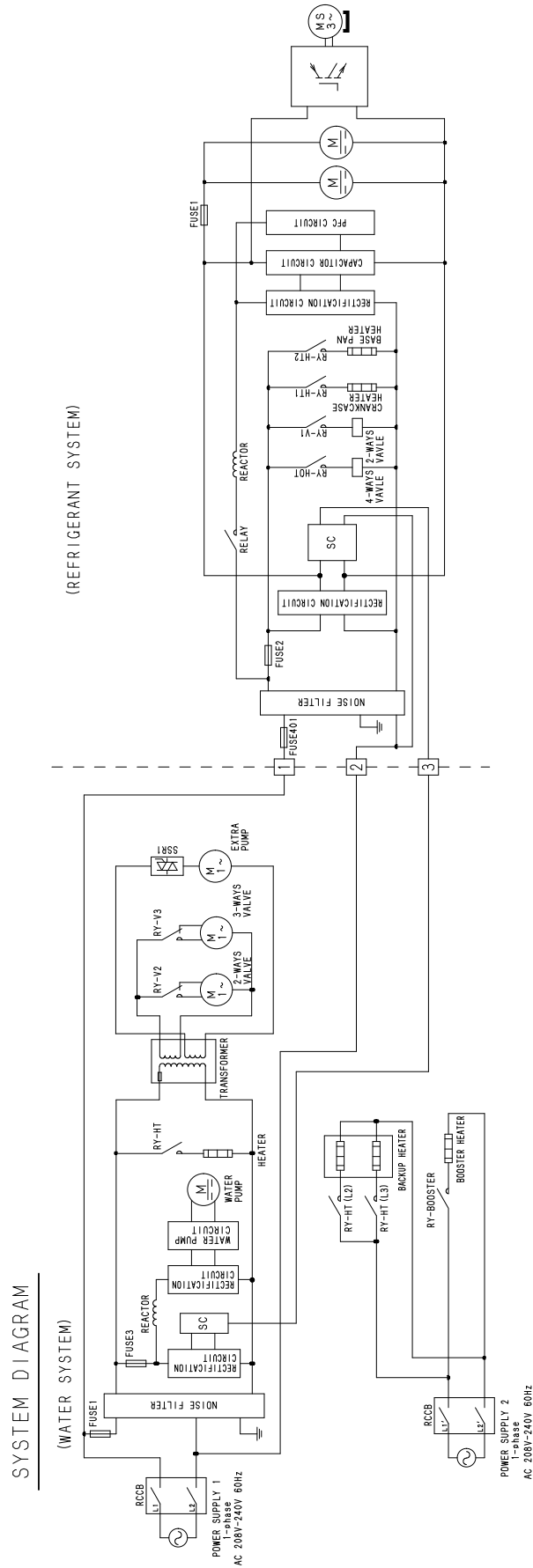

7 Diagrams

Figure 7-9 Wiring Diagram - Water System

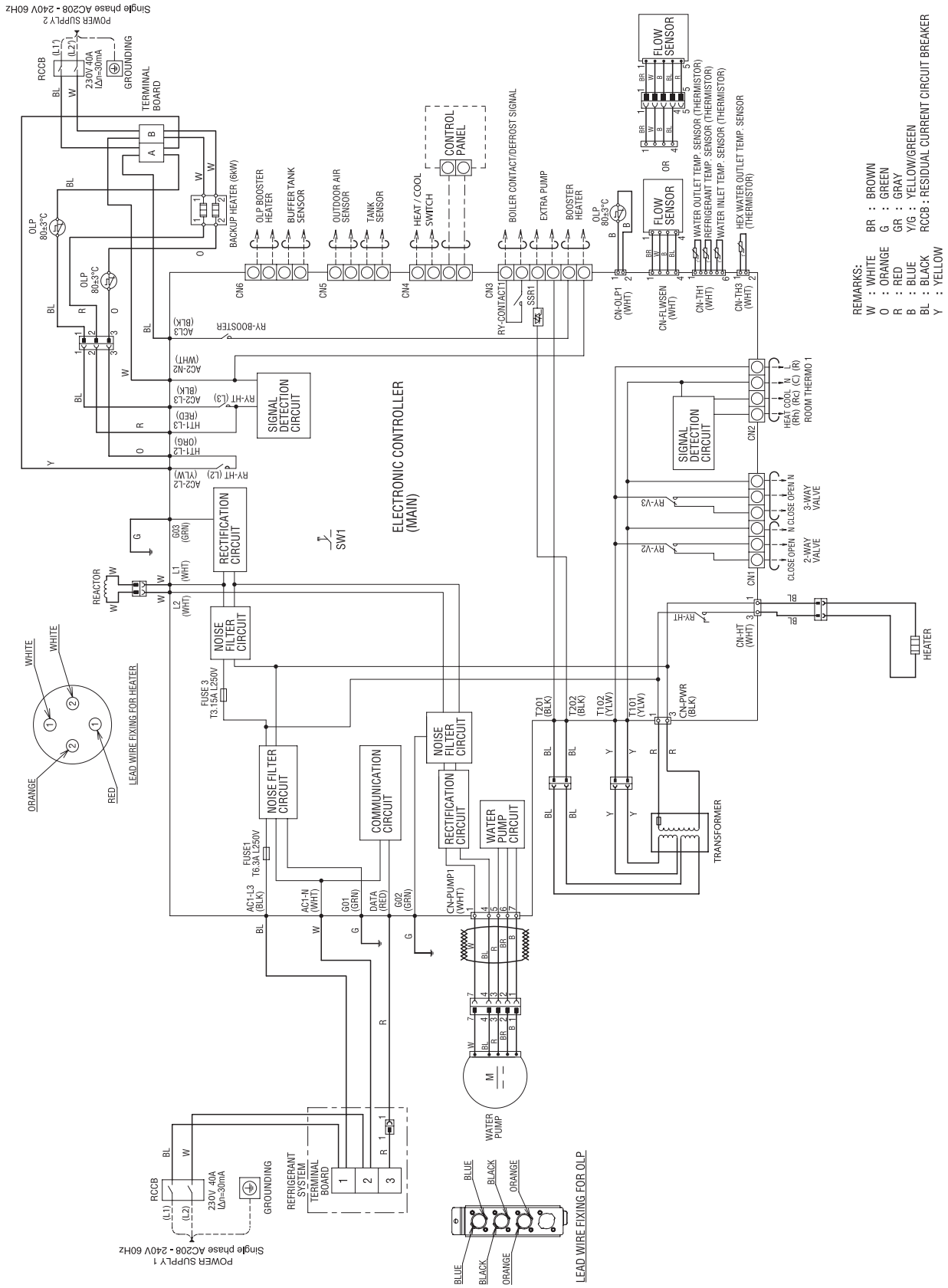

7 Diagrams

Figure 7-10 Wiring Diagram - Refrigerant System

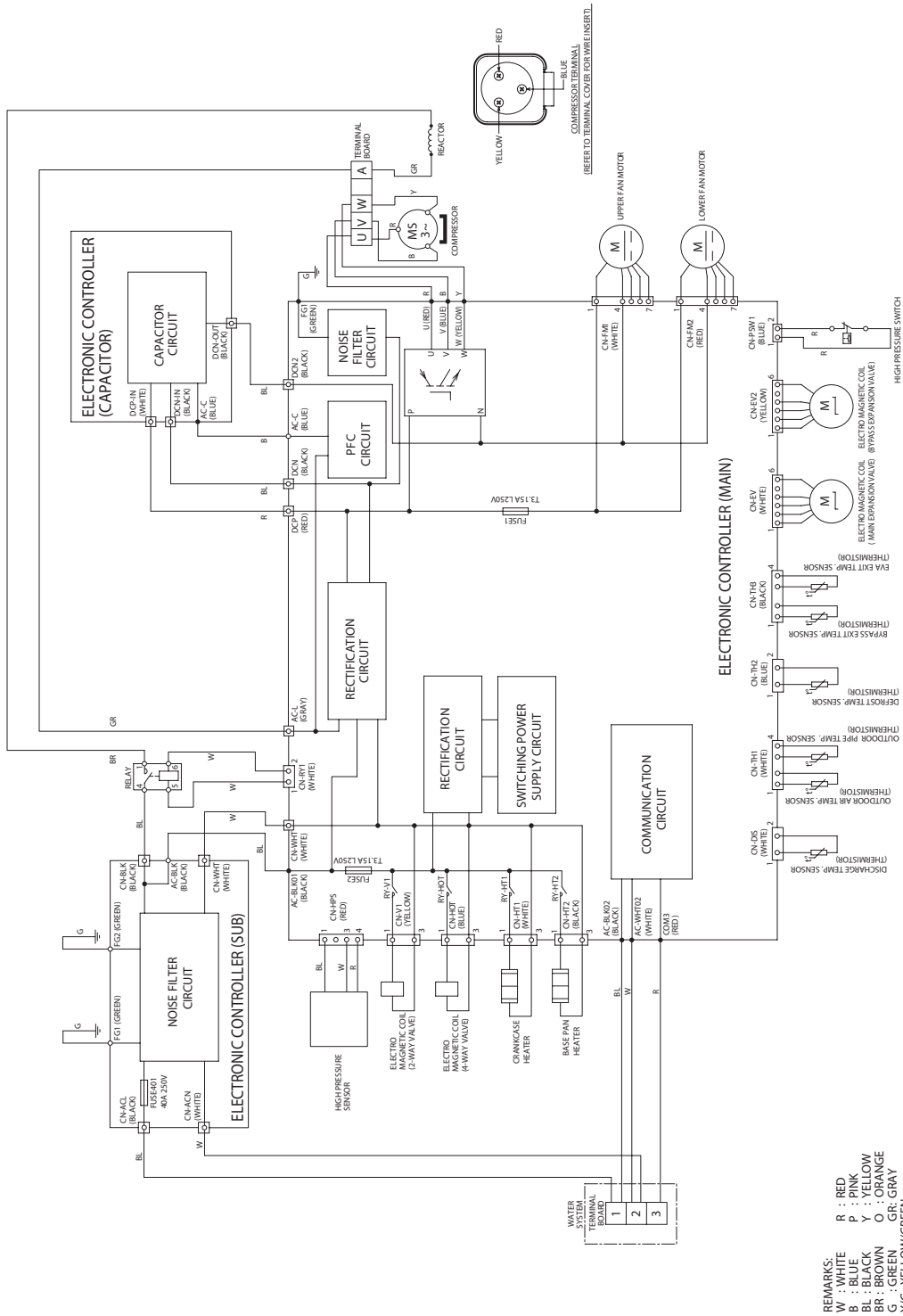

CAUTION / ATTENTION

DUE TO HIGH VOLTAGE, DO NOT TOUCH THE TERMINALS IN THE CONTROL BOARD DURING OPERATION AND 5 MINUTES AFTER SWITCHING OFF. NEXT, CONFIRM THE VOLTAGE BETWEEN RECTIFICATION DIODE BRIDGE (+) AND (-) HAS DROPPED TO BELOW 42V, BEFORE ACCESSING THE TERMINALS IN THE CONTROL BOARD.

7 Diagrams

Figure 7-11 Electronic Circuit Diagram - Water System

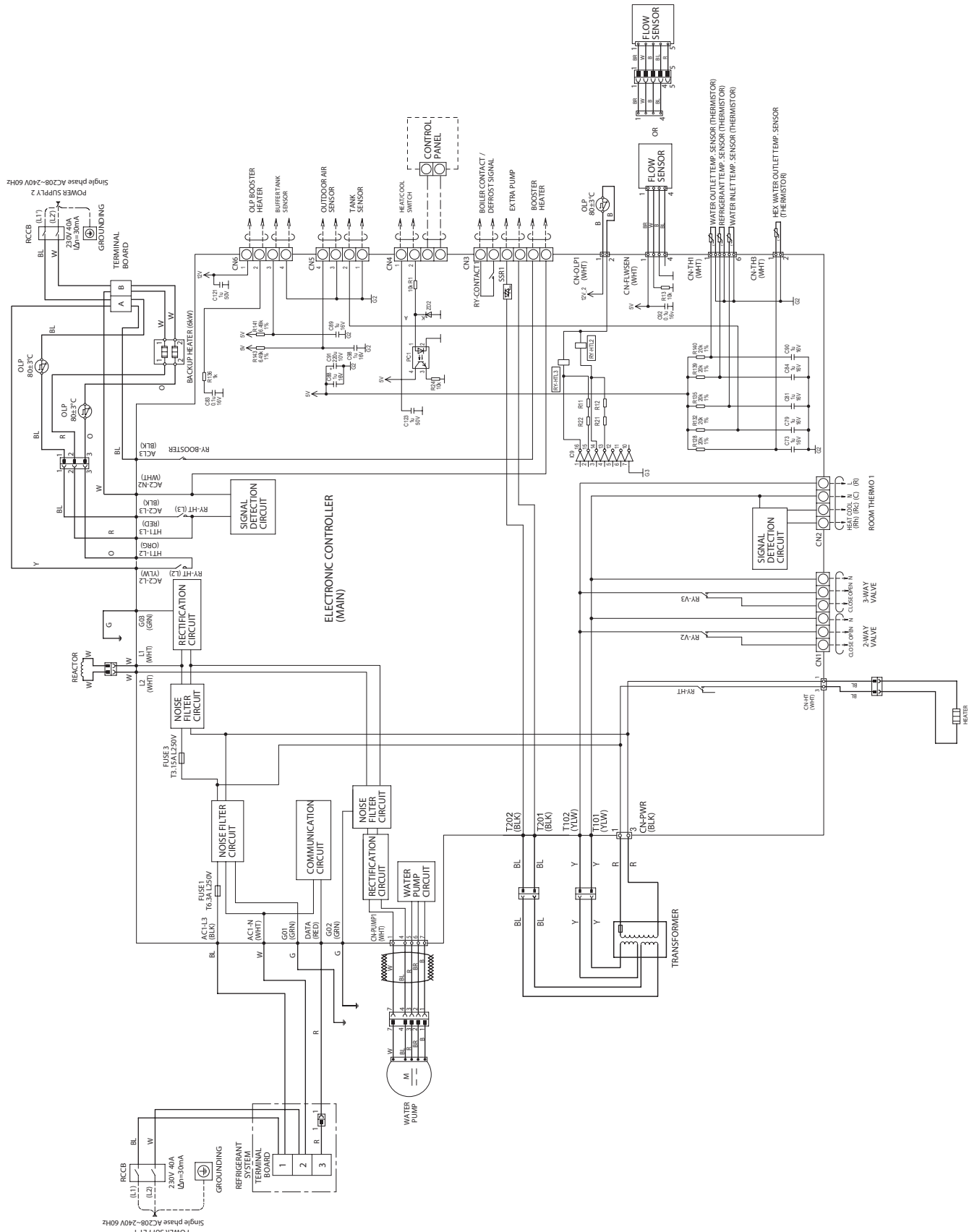

7 Diagrams

Figure 7-12 Electronic Circuit Diagram - Refrigerant System

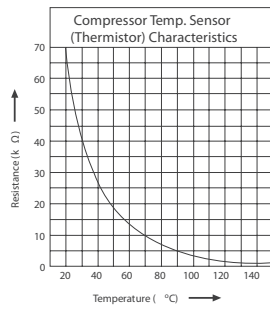
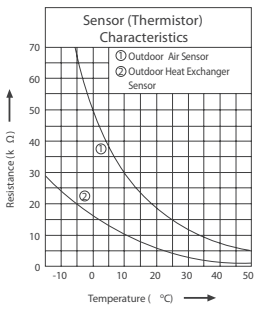
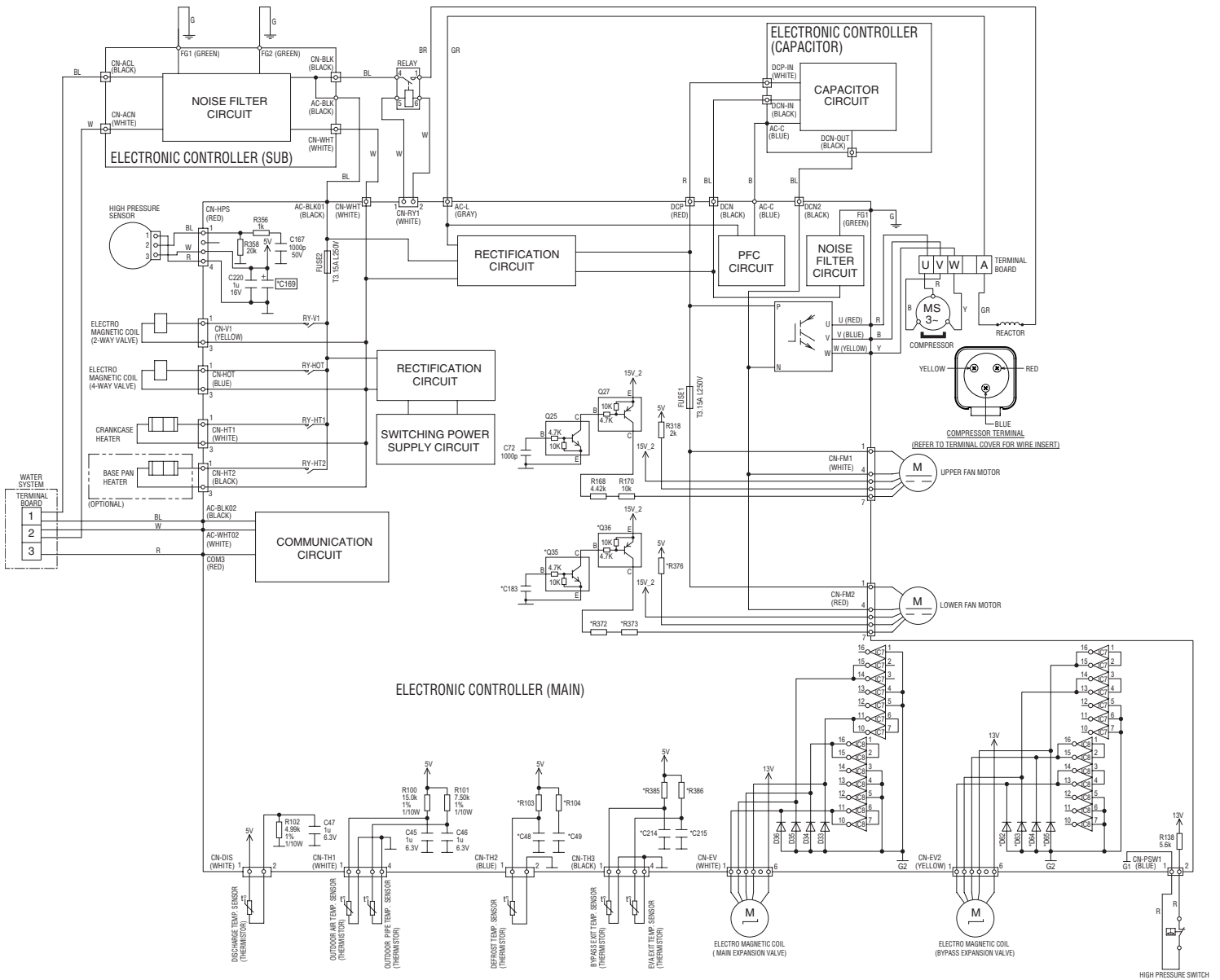

8 Circuit Boards

Figure 8-1 Main Circuit Board - Water System

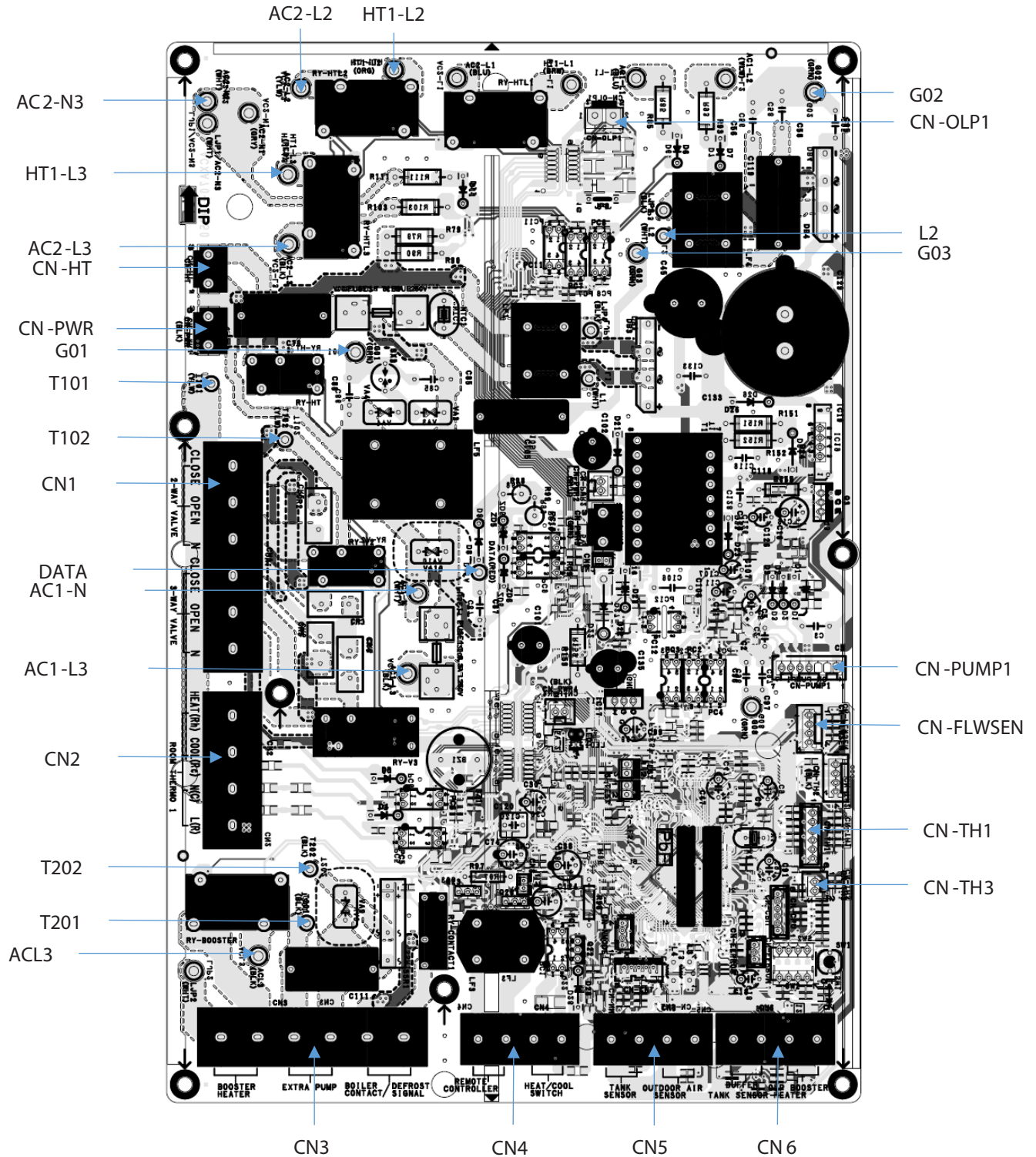

8 Circuit Boards

Figure 8-2 Main Circuit Board - Refrigeration System

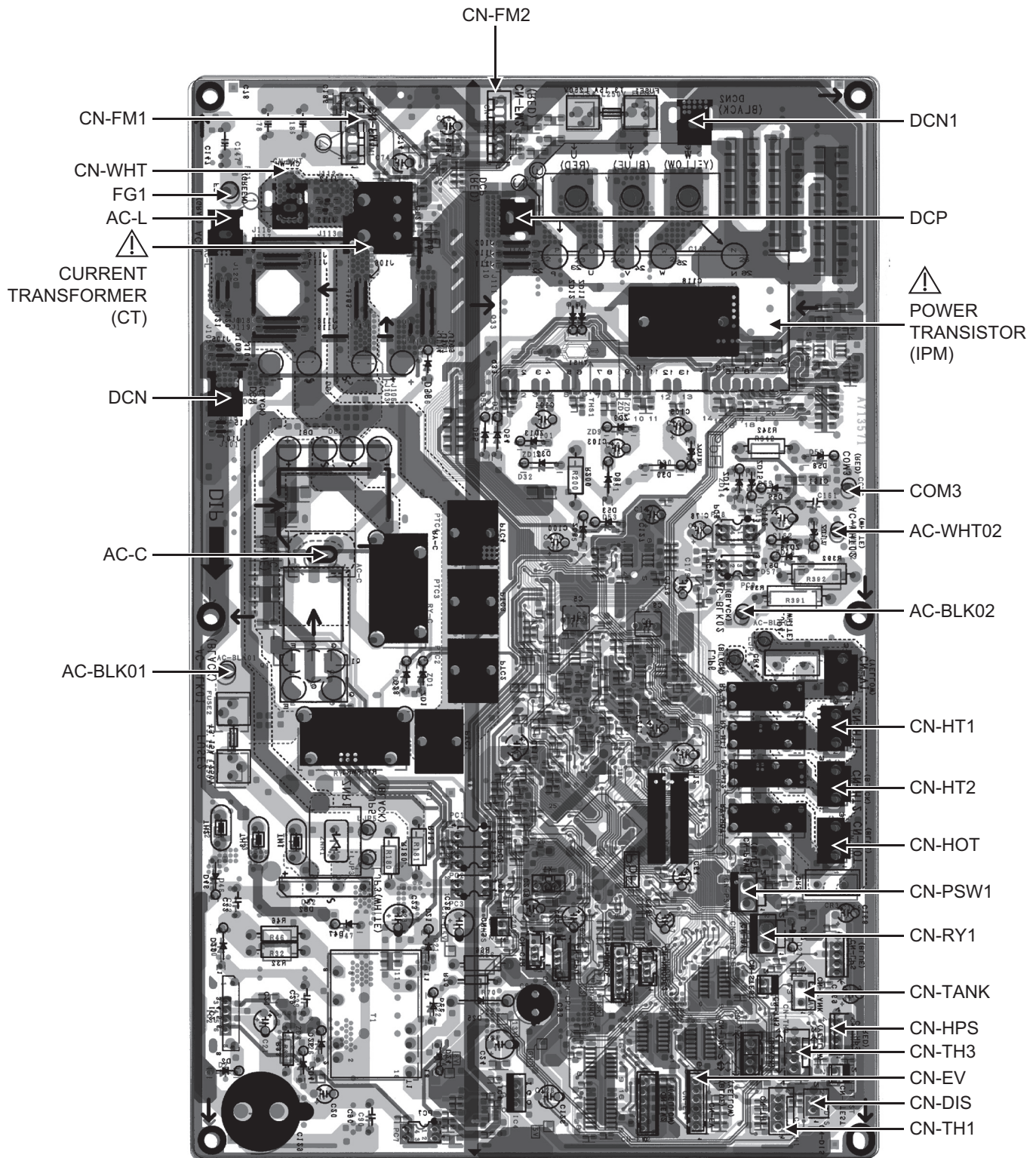

8 Circuit Boards

Figure 8-3 Capacitor Circuit Board

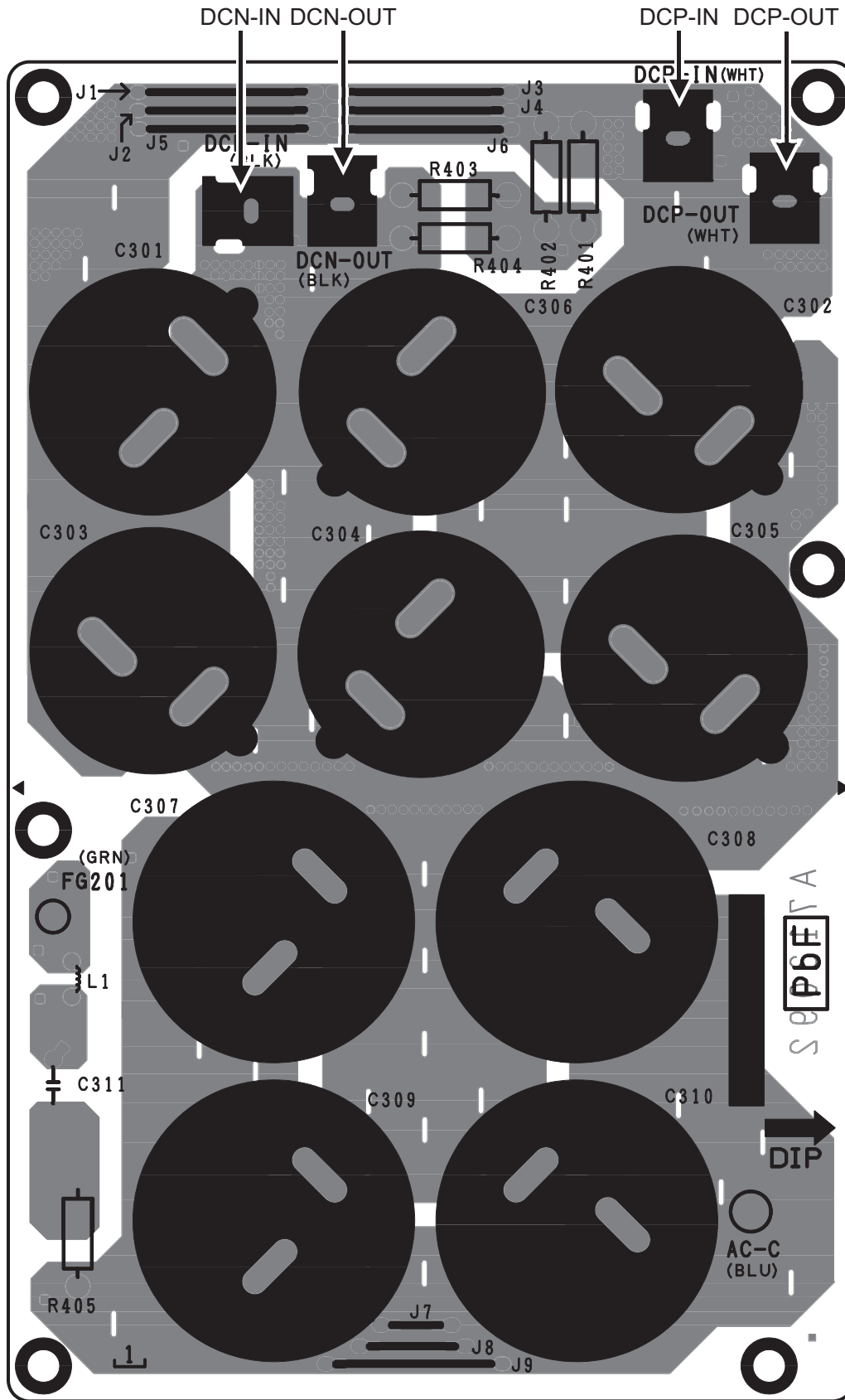

8 Circuit Boards

Figure 8-4 Noise Filter Circuit Board

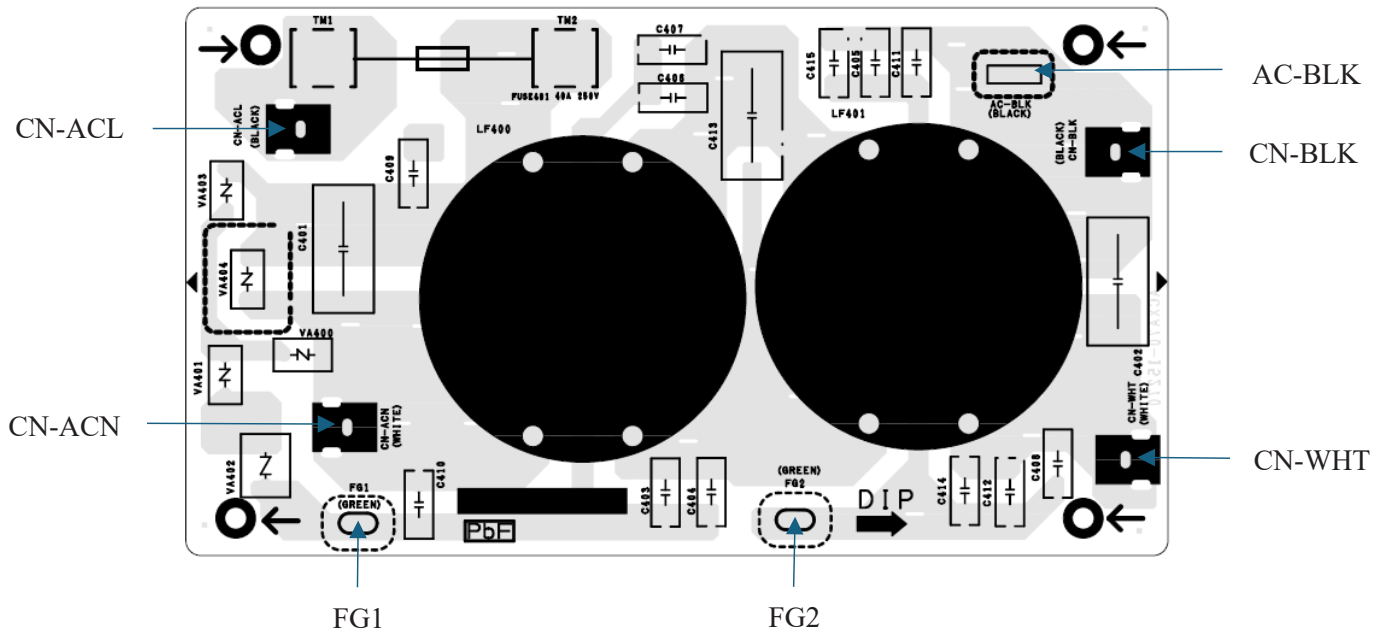

9 Installation

Handling the Mono bloc unit

The Mono bloc unit is a large and heavy unit. When handling the unit, always use lifting tools with slings. These slings can be fitted into sleeves at the unit's base frame.

Select the best location

Install the Mono bloc unit in outdoor locations only. Avoid installations in areas where the ambient temperature may drop below -4°F. The Mono bloc unit must be installed on a flat, solid surface. The installation place must be removed from any heat source or steam which may affect the operation of the Mono bloc unit.

The Mono bloc unit must be installed:

- In a location where air circulation is good.
- In a location where drainage can be easily fitted.
- In a location where the Mono bloc unit's operating noise will not disturb the user.
- In a location that is accessible for maintenance.
- In a location where flammable gas leaks will not occur.
- In a location where the Mono bloc unit's piping and wiring distances will be reasonable.

Be sure to maintain minimum spacing from the wall, ceiling, and other obstacles as illustrated in Figure 9-1.

If an awning is built over the unit to prevent direct sunlight or rain, ensure that heat radiation from the condenser is not obstructed. Do not place any obstacles which may obstruct the discharged air. Avoid installing the Mono bloc unit at a location where the air intake may be exposed directly to wind.

If the Mono bloc unit is installed near the sea, a region with high sulfur content, or an oily location (e.g., machinery oil, etc.), its lifespan may be shortened.

When installing the product in a location where it will be affected by storms or strong winds, such as wind blowing between buildings, including the rooftop of a building or a location where there are no surrounding buildings, secure the unit with cables, etc., to prevent tipping or overturning.

Mono bloc unit installation

Mono bloc unit will become heavy when filled with water. Please install the unit on a strong concrete floor bearing in mind the weight of the unit and water. Secure the Mono bloc unit on the concrete floor with 7/16" - 20 UNF anchor bolts at 4 locations. The pull-out strength of these anchor bolts must be greater than 3372 lb-ft (15000N).

Figure 9-1 Grip anchor vs Embedded anchor

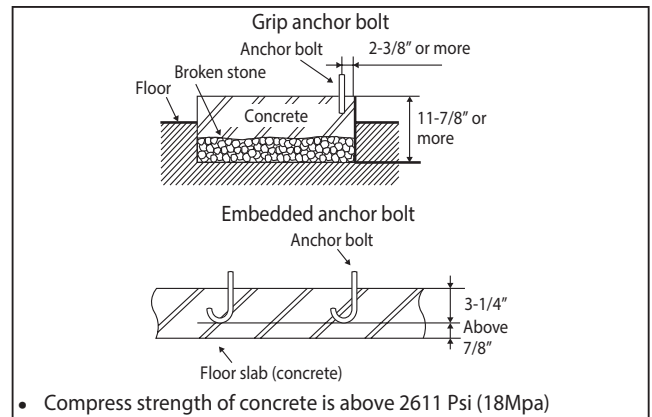

Disposal of Mono bloc unit drain water

When a drain elbow is used, it is essential to follow the points below:

- The unit should be placed on a stand that is taller than 2 inches.
- Cover the 8 holes (ø 7/8 inches) with rubber caps (see illustration below).
- Use a tray (field supply) when necessary to dispose of the Mono bloc unit drain water.

If the unit is used in an area where the temperature falls below 32°F for 2 or 3 consecutive days, it is recommended that the drain elbow and rubber caps not be used. Otherwise, the drain water will freeze and the fan will not rotate.

Figure 9-2 Unit drain

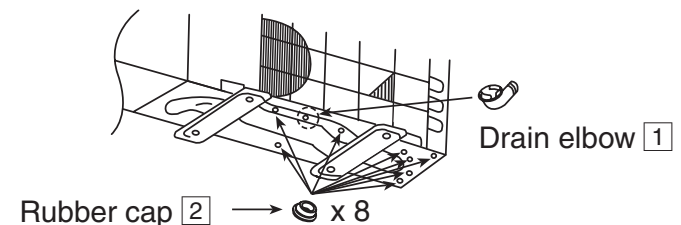

Table 9-1 Included Accessories

No.	Accessory Part	Qty.
1	Drain elbow	1
2	Rubber cap	8
3	Control pad	1
4	Outdoor sensor	1
5	Tank sensor	1
6	Buffer tank sensor	1

9 Installation

Table 9-2 Field-Supplied Accessories (optional)

No.	Part	Specification
i	Two-way valve	20 - 30VAC, 0.5A
ii	Three-way valve	20 - 30VAC, 0.5A
iii	Room thermostat	20 - 30VAC, 2VA (0.15A)
v	Extra pump	110 - 130VAC, 0.54A

Figure 9-3 Minimum distances for installation

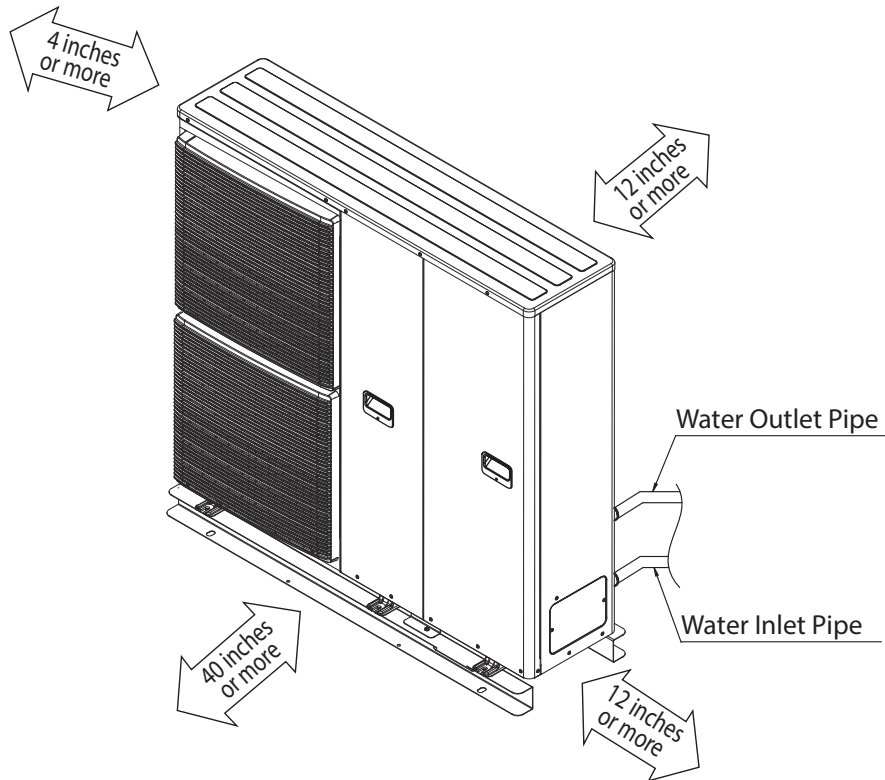

9 Installation

Piping installation

WARNING This section is for authorized and licensed electrician / water system installers only. Work behind the cabinet front panel secured by screws must only be carried out under supervision of a qualified installer or service technician.

Typical piping installation

A qualified installer or service technician must install this water circuit.

This water circuit must comply with relevant national regulations, and local building code regulations. Ensure that the components installed in the water circuit can withstand the operating water pressure. Do not apply excessive force to piping that may damage the pipes. Use a 1¼" RP nut for both the water inlet and the water outlet connections and clean all piping with tap water before connecting to the Mono bloc unit. Cover the pipe end to prevent dirt and dust from entering the pipe when inserting it through a wall. If an existing tank is to be connected to this Mono bloc unit, ensure the pipes are clean before water pipe installation is carried out.

Choose proper sealer which can withstand the pressures and temperatures of the system. Make sure to use two wrenches to tighten the connection. Tighten the nuts with a torque wrench: 86.74 lb-ft If non-brass metallic piping is used for installation, make sure to insulate the piping to prevent galvanic corrosion. Do not use pipes that are crushed or deformed. If crushed or deformed pipes are used, the unit may malfunction. Make sure to insulate the water circuit piping (insulator thickness: ¾ inches or greater) to prevent condensation during cooling operation and reduction of heating capacity, and to prevent the outdoor water circuit piping from freezing during winter.

After installation, check the water leakage condition in the connection area during test run. In case of a power supply failure or pump operating failure, drain the system. When water is idle inside the system, it is likely to freeze, which could damage the system. See Figure 9-4 for example illustration.

Figure 9-4 Unit drainage in case of power outage

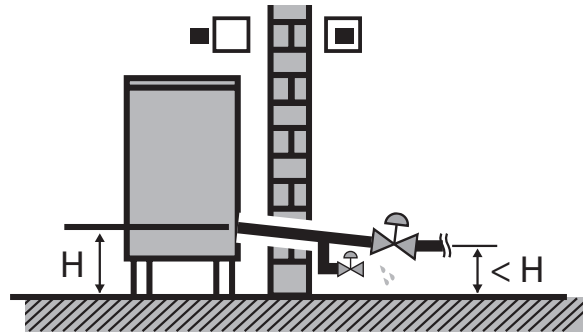

Drainage piping installation

Use a drain hose with an inner diameter of 5/8 inch. The hose must be installed in a continuously downward-sloping direction and left open to the frost-free atmosphere.

If the drain hose is long, use a metal support fixture(s) eliminate hills and valleys in the drain hose. Water will drip from this hose; therefore the outlet of this hose must be located in an area where the outlet cannot become blocked.

Do not insert this hose into a sewage or drain pipe that may generate ammonia gas, sulfuric gas, etc. If necessary, use a hose clamp to secure the hose at the drain hose connector to prevent it from leaking.

CAUTION Do not overtighten. This can cause water leakage.

Figure 9-5 Drain hose connector

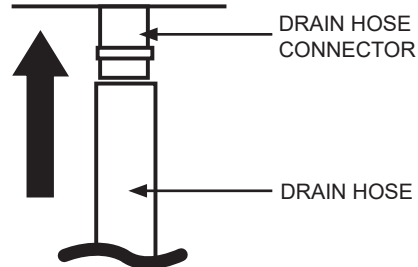

9 Installation

WARNING This section is for authorized and licensed electricians only. Work behind the cabinet front panel secured by screws must only be carried out under supervision of a qualified installer or service technician.

Remove the cabinet front panel

1. Remove the four (4) mounting screws as shown in the illustration.
2. Slide the cabinet front panel downward to release the pawls. Then, pull it toward the front to remove it.

Figure 9-6 Removing the cabinet front panel

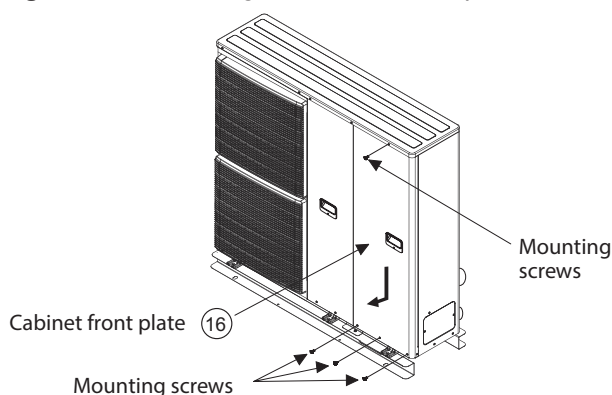

Securing the power supply cord

1. An isolator switch must be connected to the power supply cable.
2. The isolator switch (disconnecter) must have a contact gap of at least 1/8 inch.
 - Connect the approved polychloroprene-sheathed Power Supply 1 cord and Power Supply 2 cord and type designation 60245 IEC 57 or heavier cord to the terminal board; connect the other end of the cord to the isolator switch (disconnecter). See table 9-3 for cable size requirements.
 - To avoid damaging the cable and cord on sharp edges, the cable and cord must be passed through the designated holes before being connected to the terminal block.
3. Secure the cable to the control board with the holder (clamp).

Table 9-3 Cable size requirements

Model	Cable Size	Isolator switches	Recommended GFCI
RAH040	3 x min. 10 AWG	30A	30mA, 2P, type A

Figure 9-7 Unit terminal

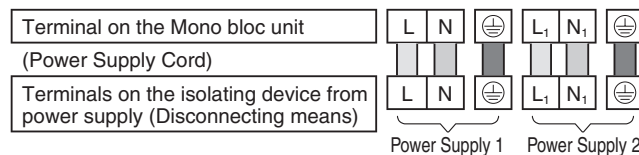
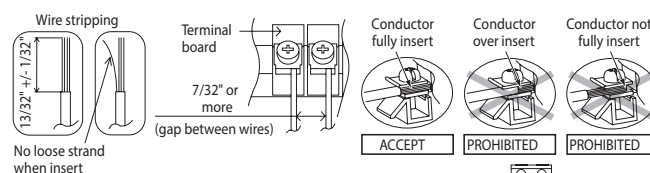
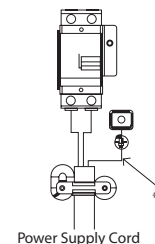

Figure 9-8 Wire stripping and connecting requirement



Terminal screw	Tightening torque lb*ft
8-32 UNC	1.158 ~ 1.446
10-24 UNC	1.446 ~ 1.807

*1 - Earth wire must be longer than other cables for safety reasons.



Connection requirement for RAH040

This equipment's Power Supply 1 complies with IEC 61000-3-12 provided that the short circuit power S_{sc} is greater than or equal to 1900kW at the interface point between the user's supply and the public power grid. It is the responsibility of the installer or user of the equipment to ensure, by consultation with the power grid operator if necessary, that the equipment is connected only to a supply with a short circuit power S_{sc} greater than or equal to 1900kW.

The equipment's Power Supply 1 complies with IEC 61000-3-11 and must be connected to a suitable supply power grid, having a service current capacity $\geq 100A$ per phase. Please confirm with the local power company that the service current capacity at the interface point is sufficient for the installation of the equipment.

This equipment's Power Supply 2 complies with IEC 61000-3-12. The equipment's Power Supply 2 complies with IEC 61000-3-11 and must be connected to a suitable supply power grid, with the following maximum permissible system impedance: $Z_{max} = 0.193 \text{ ohm } (\Omega)$ at the interface.

Please confirm with the local power provider to ensure that the Power Supply 2 is connected only to a supply whose impedance is less than the unit's rated value.

9 Installation

Connection requirement for RAH040

All connections must adhere to national and local wiring codes. It is strongly recommended that manufacturer-recommended parts and accessories be used for installation.

For connection to main circuit board:

1. Two-way valve connection is 20 - 30VAC, with a 0.5A maximum. Wires must be at minimum 16AWG with type designation 60245 IEC 57 or heavier, or similarly double-insulated, sheathed cables.
2. Three-way valve connection is 20 - 30VAC, with a 0.5A maximum. Wires must be at minimum 16AWG, with type designation 60245 IEC 57 or heavier, or similarly double-insulated, sheathed cables.
3. Room Thermostat connection is 20 - 30VAC, with a 0.15A maximum. Wires must be at minimum 22AWG, with type designation 60245 IEC 57 or heavier, or similarly double-insulated, sheathed cables.
4. Maximum output power of booster heater must be ≤ 3 kW. Booster heater connection is 208 - 240VAC, with a 13A maximum. Wires must be at minimum 12AWG, with type designation 60245 IEC 57 or heavier.
5. Extra pump connection is 110 - 130VAC, with a 0.54A maximum. Wires must be at minimum 16AWG, with type designation 60245 IEC 57 or heavier.
6. Boiler contact/Defrost signal connection is 120/240VAC, with a 3A maximum. Wires must be at minimum 16AWG, with type designation 60245 IEC 57 or heavier.
7. Heat/Cool switch connection is 24VDC, with a 0.2A maximum. Wires must be at minimum 18AWG, with a double insulation layer, of PVC-sheathed or rubber-sheathed cable.
8. Tank sensor connection is 5VDC, with a 0.2mA maximum. Wires must be at minimum 22AWG, with a double insulation layer (with insulation rating of at least 30V), of PVC-sheathed or rubber-sheathed cable.
9. Buffer tank sensor connection is 5VDC, with a 0.2mA maximum. Wires must be at minimum 22AWG, with a double insulation layer (with insulation rating of at least 30V), of PVC-sheathed or rubber-sheathed cable.
10. Outdoor air sensor connection is 5VDC, with a 0.2mA maximum. Wires must be at minimum 22AWG, with a double insulation layer of PVC-sheathed or rubber-sheathed cable.
11. OLP booster heater connection is 12VDC, with a 0.2A maximum. Wires must be at minimum 16AWG, with a double insulation layer of PVC-sheathed or rubber-sheathed cable.

Figure 9-9 Cable and cord connections

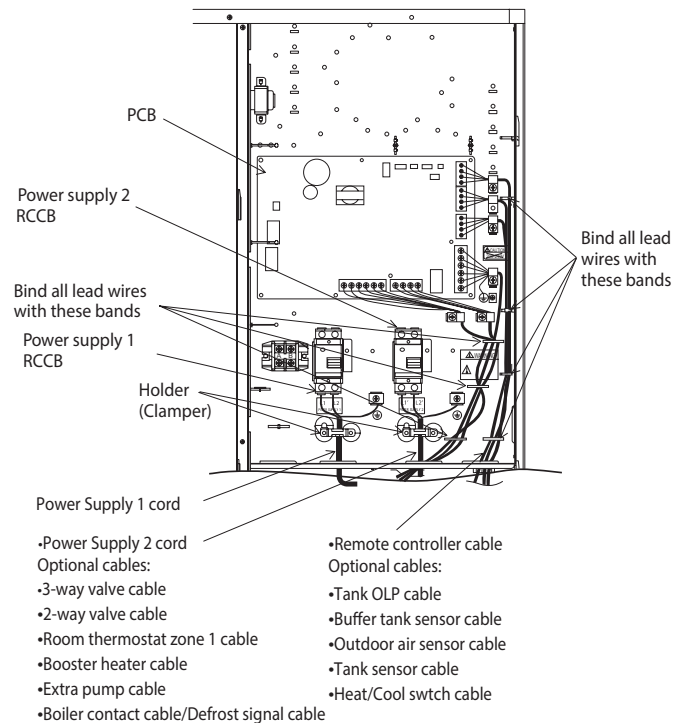

Table 9-4 Screw terminal tightening torque

Terminal screw on PCB	Maximum tightening torque lb-ft
4-40 UNC	0.3688
8-32 UNC	0.8851

Installing the control pad

Installation location

Install at a height of 3-1/4 to 5 feet from the floor at a location where the average room temperature can be detected). Install vertically against the wall.

Avoid the following locations for installation:

1. By a window, etc. exposed to direct sunlight or direct air.
2. In the shadow of or behind objects that deviate airflow in the room.
3. Locations where condensation occurs (the control pad is not waterproof or moisture-resistant).
4. Locations near a heat source.
5. On an uneven surface.

Maintain a distance of at least 3-1/4 feet from TVs, radios and PCs (interference may cause fuzzy image or noise).

9 Installation

Control pad wiring

The control pad connection is 16VDC, with a 25mA maximum. Wires must be at minimum 22AWG, with a double insulation layer of PVC-sheathed or rubber-sheathed cable. Total cable length must not exceed 164 feet. Be careful not to connect cables to other terminals (e.g., power source wiring terminal). Malfunction may occur. Do not bundle together with the power source wiring or run in the same metal conduit. Operation error may occur.

Figure 9-10 Terminal for control pad wiring

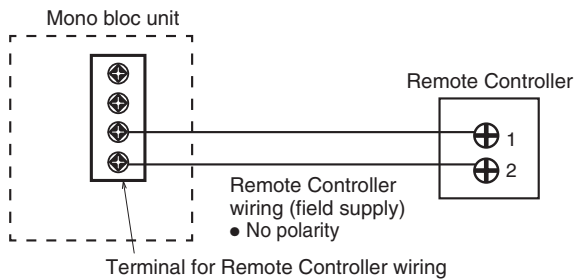

Mounting the control pad

For the exposed type, use a drill to drill two holes for the mounting screws.

Figure 9-11 Removing top cover from control pad

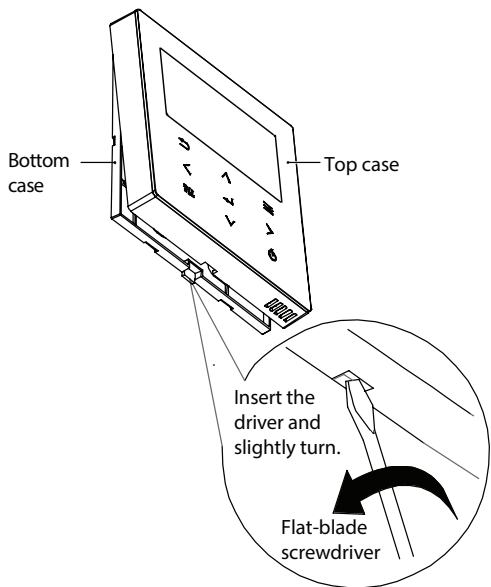

WARNING This section is for authorized and licensed electricians only. Work behind the cabinet front panel secured by screws must only be carried out under supervision of a qualified contractor, installation engineer, or service person.

Figure 9-12 Mounting instructions - exposed

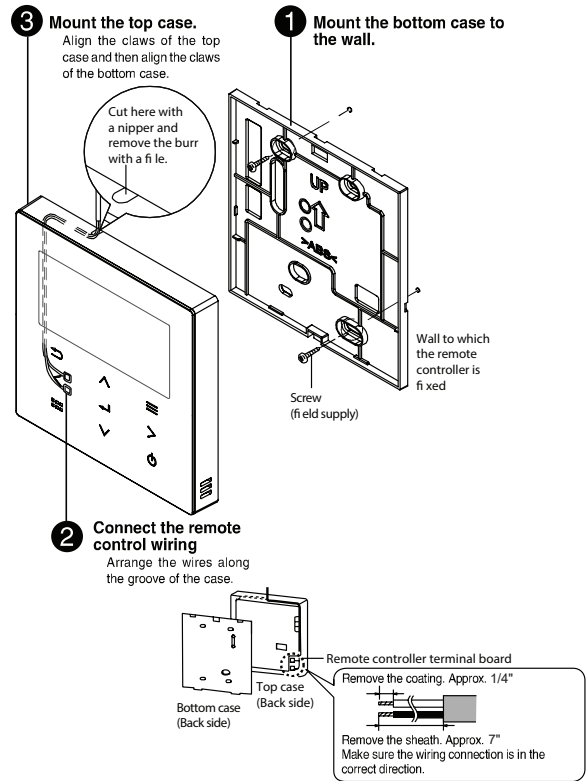

For the embedded type, use a drill to drill two holes for the mounting screws.

Figure 9-13 Mounting instructions - embedded

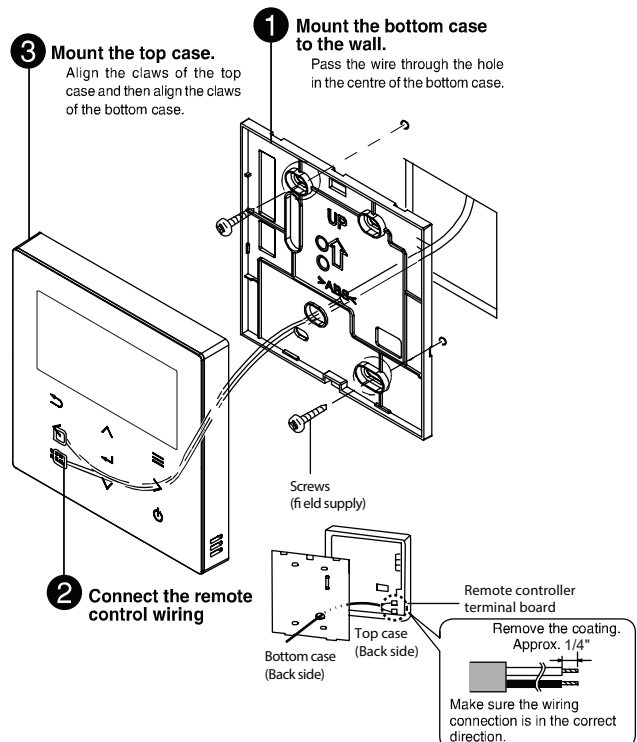

9 Installation

Charging the water

Make sure all the piping installations are properly completed before carrying out the following steps:

1. Open the cabinet front panel to access the pressure relief valve and air purge valve.
2. Turn the plug on the air purge valve outlet counterclockwise by one complete turn from the fully closed position.

Figure 9-14 Turn plug counterclockwise

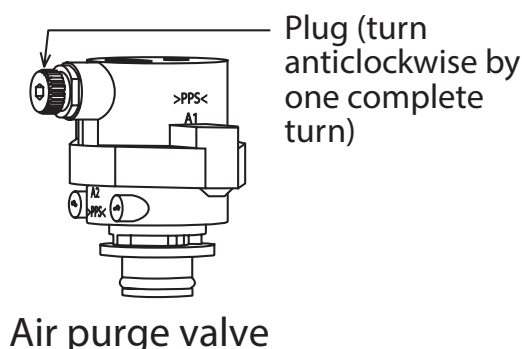

3. Set the pressure relief valve level to “DOWN.”

Figure 9-15 Pressure relief valve

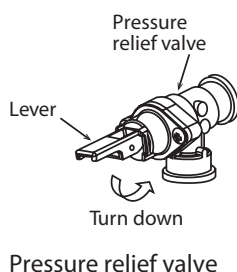

4. Start adding water (with pressure more than 15 PSI) to the Mono bloc unit via the water inlet. Stop adding water if the free water flows into the pressure relief valve drain hose.
5. Turn the power supply ON and make sure the water pump is running.
6. Check to make sure no water is leaking at the tube connection points.
7. Reinstall the cabinet front panel by tightening the 2 mounting screws.

Reconfirmation



WARNING Be sure to switch off the power supply before performing each of the processes in this section. Before opening access to terminals, all supply circuits must be disconnected.

Check water pressure

Water pressure should not be lower than 7 PSI (as reported by the water pressure gauge). If necessary add tap water to the water circuit.

Check pressure relief valve

1. Check for correct operation of Pressure Relief Valve by turning on the lever to become horizontal.
2. If you do not hear a clacking sound (due to water drainage), contact your local a qualified installer or technician.
3. Push the lever to the down position after completing the check.
4. If water keeps draining from the unit, switch the system off, and then contact your local qualified installer or technician.

Expansion vessel pre-pressure check

1. The Mono bloc unit has a built-in expansion vessel with a capacity of 2.64 gallons and initial pressure of 15 PSI.
2. Without an antifreeze agent, the total amount of water in the system should be below 52.83 gallons.
3. If the total amount of water is more than 52.83 gallons, please add an expansion tank (field supply).
4. If using an antifreeze agent, the expansion rate ϵ is different depending on manufacturer.
5. Please refer to the antifreeze manufacturer for the expansion rate ϵ before calculating the maximum water volume of the system.
6. The expansion tank capacity required for the system can be calculated from the formula below.

$$V = \frac{\epsilon \times V_0}{(P_0/P_1) - (P_0/P_2)}$$

V : Required gas volume <expansion vessel volume Gallons>

V_0 : System total water volume <Gallons>

ϵ : Expansion rate

P_1 : Starting system pressure (PSI)

P_2 : Final system pressure (PSI)

P_0 : Initial pressure (PSI)

- It's advised to add 10% margin for required volume of calculation.

If the height difference between the Mono bloc unit and the highest point of the system water circuit (H) is more than 23 feet, please adjust the initial pressure of the expansion tank (P_0) using the following formula:

$$P_0 = (1.45 \times H + 4.35) \text{ PSI}$$

Check RCCB

Ensure the RCCB is set to “ON” before checking the RCCB. Turn the power supply to the Mono bloc unit on. This test can only be performed when power is supplied to the Mono block unit.

9 Installation

WARNING

Be careful not to touch parts other than the RCCB test button when the power is supplied to the Mono bloc unit. Touching the Mono bloc unit while powered could result in electric shock.

Push the “TEST” button on the RCCB. The lever will turn down and indicate “0” if it is functioning normally. Contact an authorized installer or technician if the RCCB malfunctions.

Turn off the power supply to the Mono bloc unit.

If the RCCB is functioning normally, set the lever to “ON” again after testing is complete.

This product contains fluorinated greenhouse gases. Refrigerant type: R32 (GWP = 675) for RAH040

Amount: 3.53 lbs (1.080 ton CO2 equivalent)

Test run

1. Before the test run, make sure the following items have been verified:
 - Pipe work has been done correctly.
 - Electric cable connections have been made correctly.
 - Mono bloc unit has been filled with water and trapped air has been released.
2. Antifreeze agent must be added into the water circuit to prevent water from freezing when outdoor ambient temperatures are low.
 - Recommended antifreeze: Propylene glycol: 40% (equivalent to -4°F)
3. Turn the Mono bloc unit and RCCB ON.

NOTICE

During winter, turn the power supply on and leave the unit in stand-by mode for at least 15 minutes before performing the test run. Allow sufficient time for the refrigerant to warm up and prevent an incorrect error code from triggering.

4. For normal operation, water pressure gauge reading should be between 7 PSI and 43.5 PSI.
5. After the test run, clean the magnetic water filter set. Reinstall it after cleaning.

Air purge valve test run

Before performing a test run of the water circulation circuit, loosen the plug on the air purge valve on the unit by turning it counterclockwise and be sure to thoroughly release any air from the drain plugs on each terminal.

During air purging, keep water pressure applied to the circulation circuit by supplying water to the circuit. (If the water pressure drops, the air cannot be discharged sufficiently.) In particular, when the three-way valve switches from the heating circuit to the tank circuit five minutes after the air purge operation begins, the air that has accumulated in the heat exchanger inside the tank may flow into the pump, causing it to run dry. If this happens, please quickly remove the air from the circulation circuit by releasing the air from the drains located at the back of the mono bloc unit.

Figure 9-16 Air purge valve

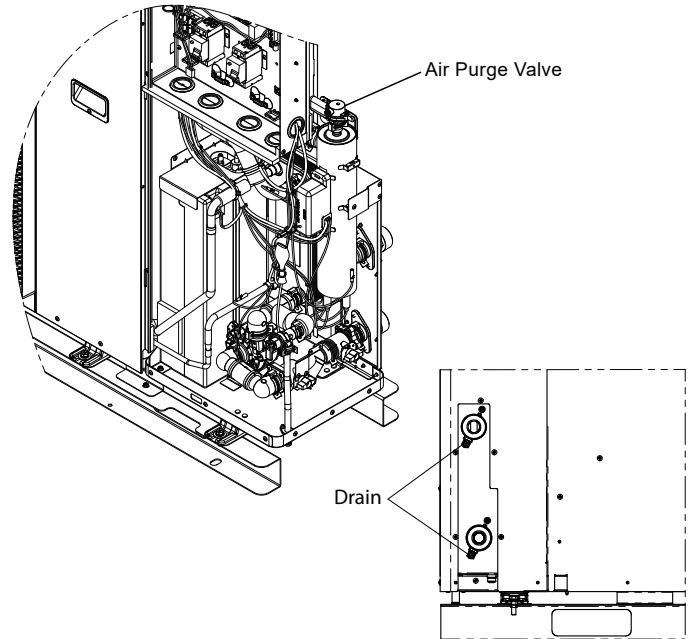
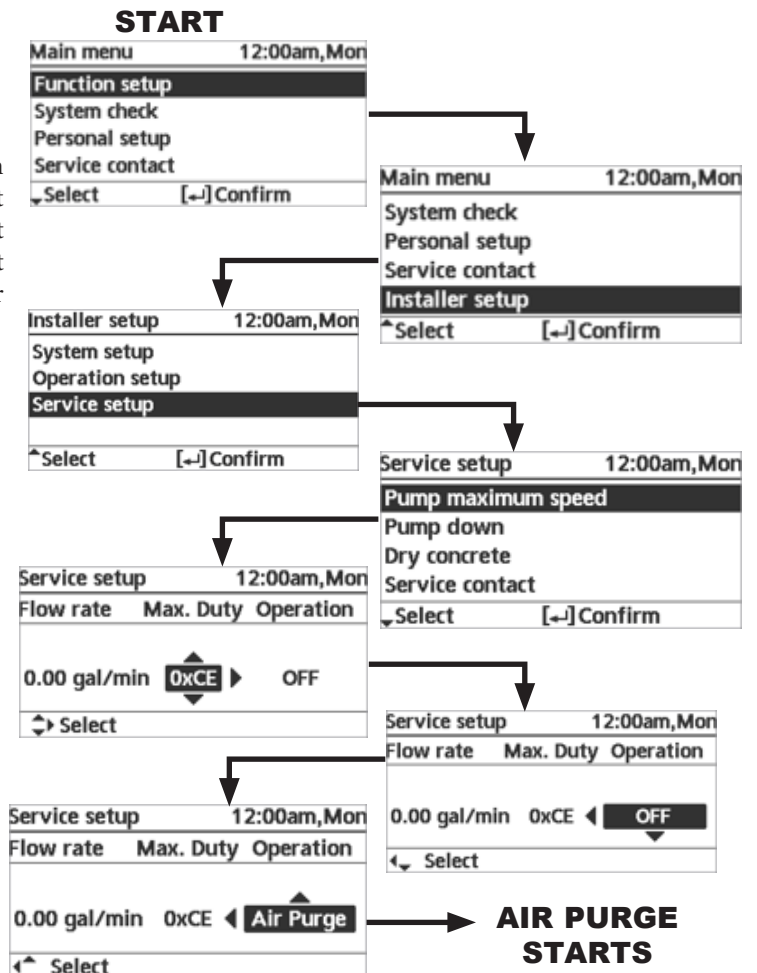



Figure 9-17 Air purge valve screens - step by step



9 Installation

NOTICE

If the pump is left running dry for a long period of time, it may cause the pump to malfunction.

Once all the air has been purged from the water circulation circuit, i.e., when the flow rate remains constant for a certain period of time, turn the pump OFF by pressing , then press Menu to end the air purge. After the air purge operation, carry out normal operation, and when you can no longer hear the sound of air flowing from the water circulation circuit, turn the air purge valve plug clockwise to tighten it.

Check water flow or water circuit

Confirm the maximum water flow during main pump operation is no less than 3.96 GPM. Water flow can be checked through the service setup. Heating operation at low water temperature with lower water flow may trigger “H75” during the defrost process.

Reset the overload protector

The overload protector prevents the water from over heating. If the overload protector trips at high water temperature, take the following steps to reset it:

1. Remove the cover.
2. Use a test pen to gently push the center of the button to reset the overload protector.
3. Secure the cover in its original position.

Figure 9-16 Overload protector

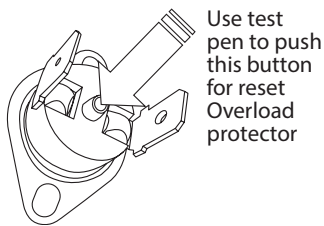

System variations

This section introduces various system variations using air-to-water heat pump and actual setting methods.

Temperature setting variation for heating

Control pad

Connect floor heating or radiator directly to the Mono bloc. This is the basic form of the simplest system.

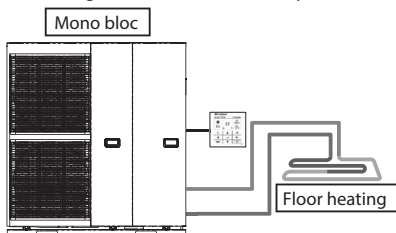

Setting of remote controller

Installer setting
System setup

Zone & Sensor:
Water temperature

Maintenance

In order to ensure optimal performance of the unit, seasonal inspections of the unit, functional check of the RCCB, field wiring, and piping must be carried out at regular intervals. This maintenance should be carried out by a qualified installer or service technician.

Maintenance for magnetic water filter set

1. Remove the cover by loosening the mounting screws to access the magnetic water filter set.
2. Turn power supply OFF.
3. Set the two valves for the magnetic water filter set to “CLOSE.”
4. Remove the clip, then gently pull the mesh out. A small amount of water may drain out.
5. Clean the mesh with warm water to remove all residue. Use a soft brush if necessary.
6. Reinstall the mesh in the magnetic water filter set and clip it back on.
7. Set the two valves for the magnetic water filter set to “OPEN.”
8. Turn power supply ON.
9. After cleaning, reinstall the cover by tightening the mounting screws securely.

Figure 9-17 Remove/reinstall cover

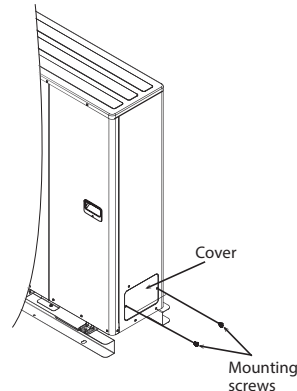

9 Installation

Room Thermostat

Connect floor heating or radiator directly to the Mono bloc. Install the control pad in the room where floor heating is installed. This is an application that uses the control pad as a room thermostat.

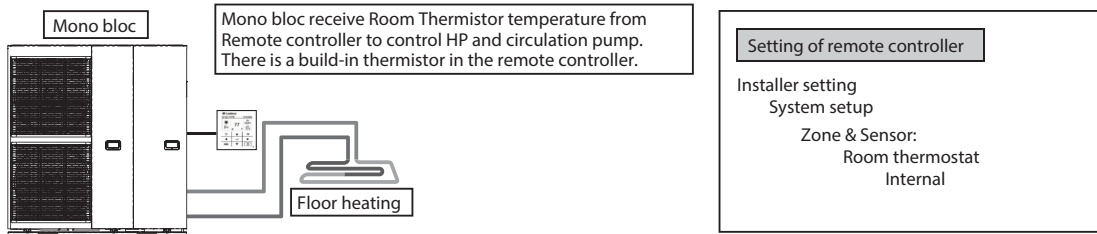

External room thermostat

Connect floor heating or radiator directly to the Mono bloc. Install a separate external room thermostat (field supply) in the room where floor heating is installed. This is an application that uses an external room thermostat.

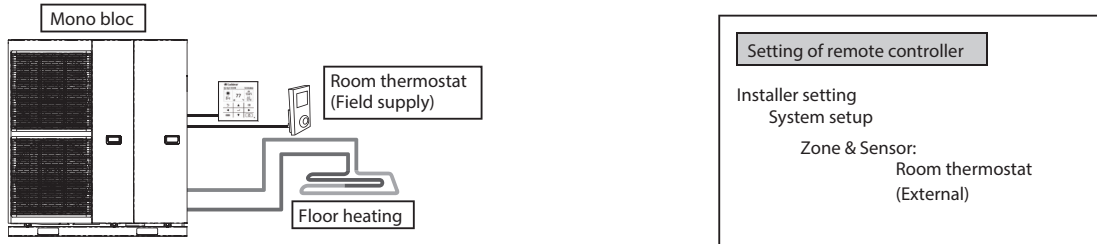

Installation examples - Systems with optional equipment

DHW (Domestic Hot Water) tank connection

This is an application that connects the DHW tank to the Mono bloc via the three-way valve.

The temperature of water in the DHW tank is detected by the tank thermistor (specified by the manufacturer).

Figure 9-18 DHW tank system connection

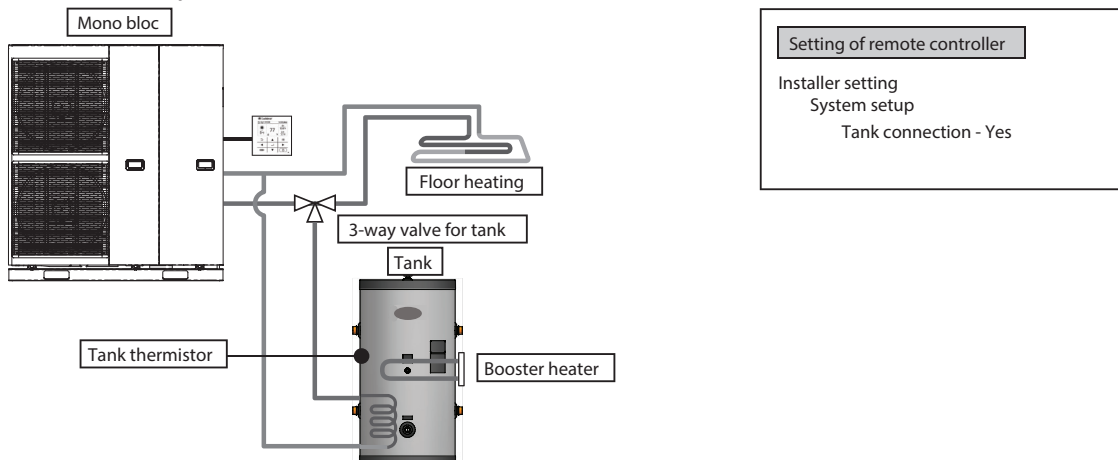

9 Installation

Buffer tank connection

This is an application that connects the buffer tank to the Mono bloc. The temperature in the buffer tank is detected by the buffer tank thermistor (specified by the manufacturer).

Figure 9-19 Buffer tank system connection

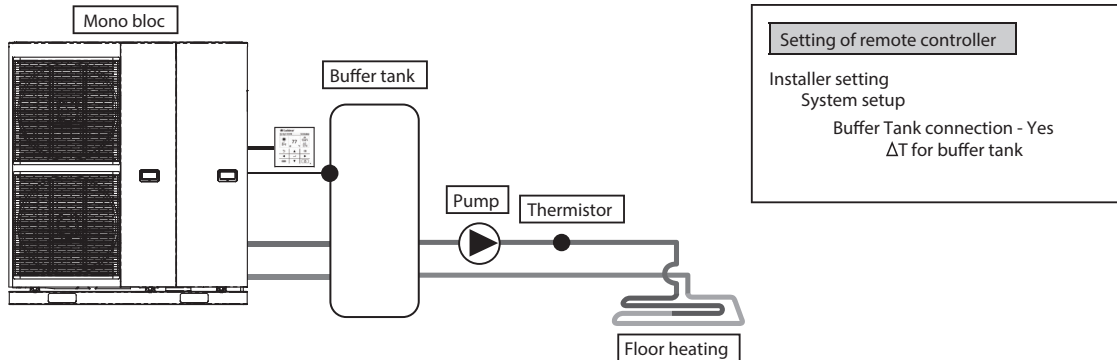

Boiler connection

This is an application that connects the boiler to the Mono bloc to compensate for insufficient capacity to heat by operating the boiler when the outdoor temperature drops and the heat pump capacity is insufficient.

The boiler is connected to the heating circuit in parallel with the heat pump. There are 3 modes that can be selected on the control pad for boiler connection. In addition, an application that connects to the DHW tank circuit to heat up the hot water in the tank is also possible.

(The installer is responsible for setting the operation of the boiler.)

Depending on the boiler settings, it is recommended that the buffer tank be installed, as the temperature of circulating water may increase. (It must be connected to the buffer tank, especially when selecting the Advanced Parallel setting.)

Figure 9-20 Boiler system connection

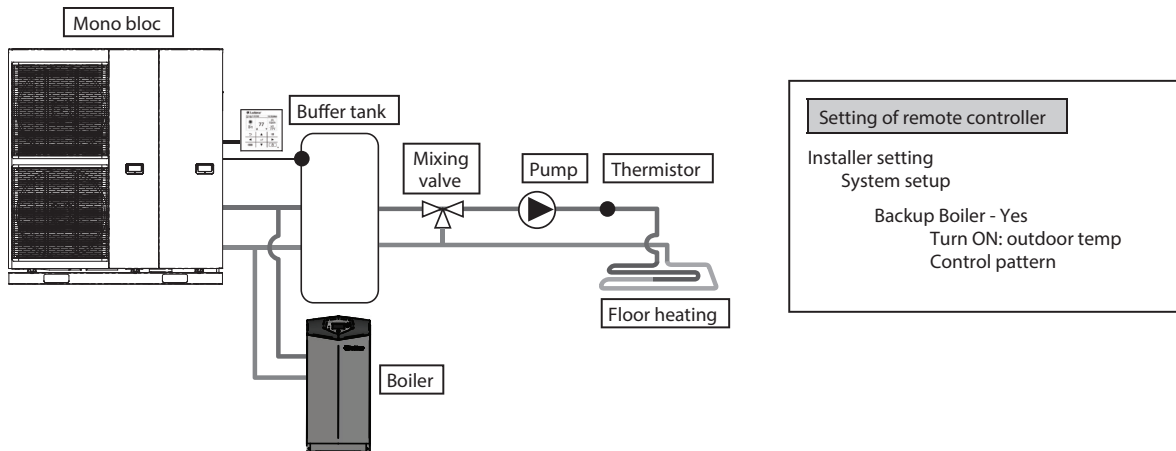

CAUTION Make sure the boiler and its integration in the system comply with applicable legislation. Make sure the return water temperature from the heating circuit to the Mono bloc does NOT exceed 131°F. The boiler is turned off by a safety control when the water temperature in the heating circuit exceeds 185°F.

WARNING Lochinvar is NOT responsible for incorrect or unsafe installations of boiler systems.

9 Installation

Attaching external devices

Length of connecting cables

When connecting cables between the Mono bloc and external devices, the length of the cables must not exceed the maximum lengths shown in the following table.

Table 9-5 Cable length limits

External Device	Maximum cable length (ft)
Two-way valve	164
Three-way valve	164
Room thermostat	164
Booster heater	164
Extra pump	164
Boiler contact / Defrost signal	164
Tank sensor	98
Outdoor air sensor	98
Tank OLP	98
Buffer tank sensor	98
Heat/Cool switch	98

Figure 9-21 Main PCB connections

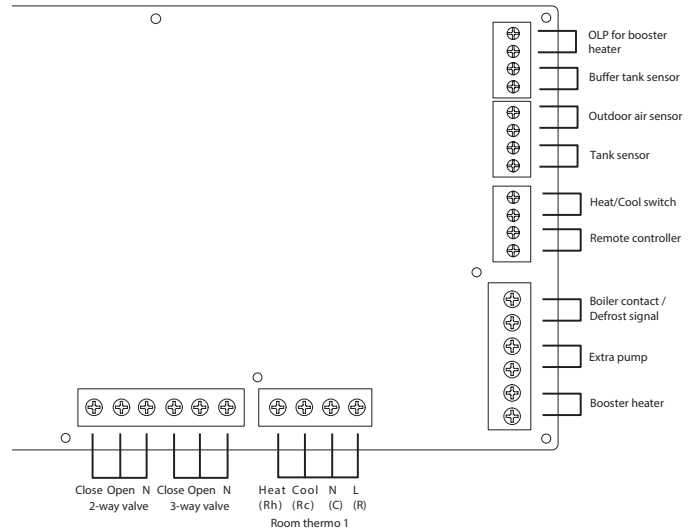

Table 9-6 PCB connections

Signal Inputs	Room Thermostat 1	L N = 24VAC, Heat, Cool = Enable Dry Contact Terminals
	OLP for booster heater	Dry contact Vcc-Bit1, Vcc-Bit2 open/short (system setup necessary) It is connected to the safety device (OLP) of DHW tank.
	Control pad	16VDC (Please use 2 core wire for relocation and extension.)
Outputs	Three-way valve	24VAC N = Neutral Open, Close = direction (for circuit switching when connected to the DHW tank)
	Two-way valve	24VAC N = Neutral Open, Close (prevents water circuit pass through during Cooling Mode)
	Extra pump	120VAC (Used when Mono bloc pump capacity is insufficient.)
	Booster heater	240VAC (Used when using booster heater in DHW tank.)
	Boiler contact / Defrost signal	Dry contact (system setup necessary)
Thermistor Inputs	Outdoor air sensor	5VDC
	Tank sensor	5VDC

9 Installation

Control pad display

Figure 9-22 Control pad

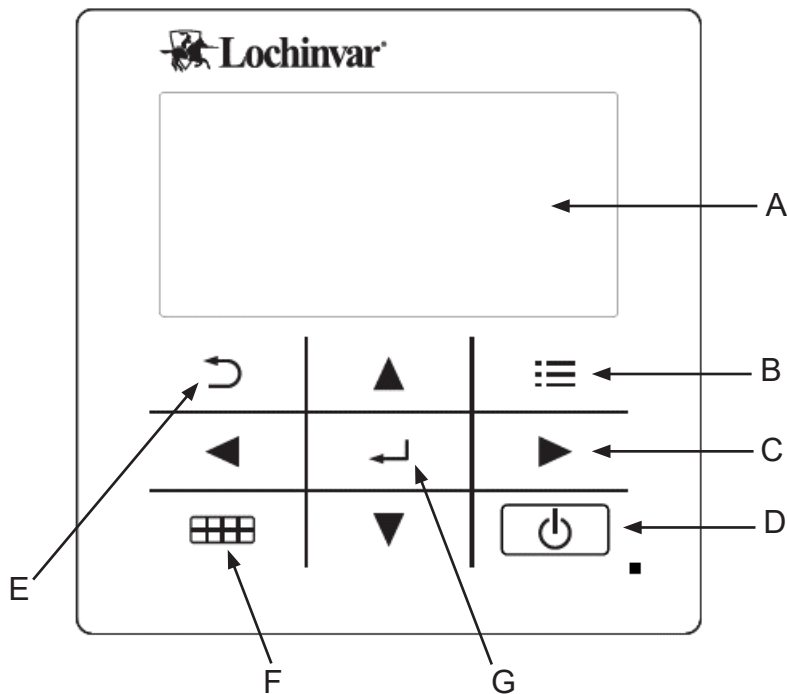

DIAGRAM LOCATION	NAME	FUNCTION
A	Main screen	Display information
B	Menu	Open/Close main menu
C	Arrow keys (Move)	Select or change item
D	Power On/Off	Start/Stop operation
E	Go back	Go back to previous item
F	Quick Menu	Open/Close quick menu
G	OK	Confirm

9 Installation

Figure 9-23 Control pad home screen

1: Function icon

Name	Function
1: Function icon	Display set function/status
	Holiday mode
	Weekly timer
	Quiet mode
	Remote controller room thermostat
	Powerful mode
	Room heater
	Tank heater
	Backup boiler

2: Mode

Icon	Mode
	Heating
	Cooling
	Auto
	Hot water supply
	Heat pump operating
	Auto heating
	Auto cooling

3: Temp setting

Icon	Temp setting
	Set room temp
	Compensation curve
	Set direct water temp

4: Display Heat temp Display current heating temperature (it is set temperature when enclosed by line)

5: Display tank temp Display current tank temperature (it is set temperature when enclosed by line)

6: Outdoor temp Display outdoor temp

Figure 9-24 Control pad initialization

<p>Initialization 12:00am,Mon</p> <p>Initializing.</p> <p>«</p>	<p>When power is ON, firstly initialization screen appears (10 sec)</p>
<p>12:00am,Mon</p> <p>[Start]</p> <p>«</p>	<p>When initialization screen ends, it turns to normal screen.</p>
<p>Language 12:00am,Mon</p> <p>ENGLISH</p> <p>FRANÇAIS</p> <p>Select [Confirm]</p> <p>« Set language & confirm</p>	<p>When any button is pressed, language setting screen appears. (NOTE) If initial setting is not performed, it does not go into menu.</p>
<p>Clock format 12:00am,Mon</p> <p>24h</p> <p>am/pm</p> <p>Select [Confirm]</p> <p>« Set time display & confirm</p>	<p>When language is set, setting screen of time display appears (24h/am/pm)</p>
<p>Date & time 12:00am,Mon</p> <p>Year/Month/Day Hour : Min</p> <p>2020 / 01 / 01 12 : 00</p> <p>Select [Confirm]</p> <p>« Set YY/MM/DD/Time & confirm</p>	<p>YY/MM/DD/Time setup screen appears</p>
<p>12:00am,Mon</p> <p>[Start]</p> <p>« Press menu, select Installer setup</p>	<p>Back to initial screen</p>
<p>Main Menu 12:00am,Mon</p> <p>System check</p> <p>Personal setup</p> <p>Service contact</p> <p>Installer setup</p> <p>Select [Confirm]</p> <p>« Confirm to go into Installer setup</p>	

9 Installation

System setup

Figure 9-25 Control pad flowchart

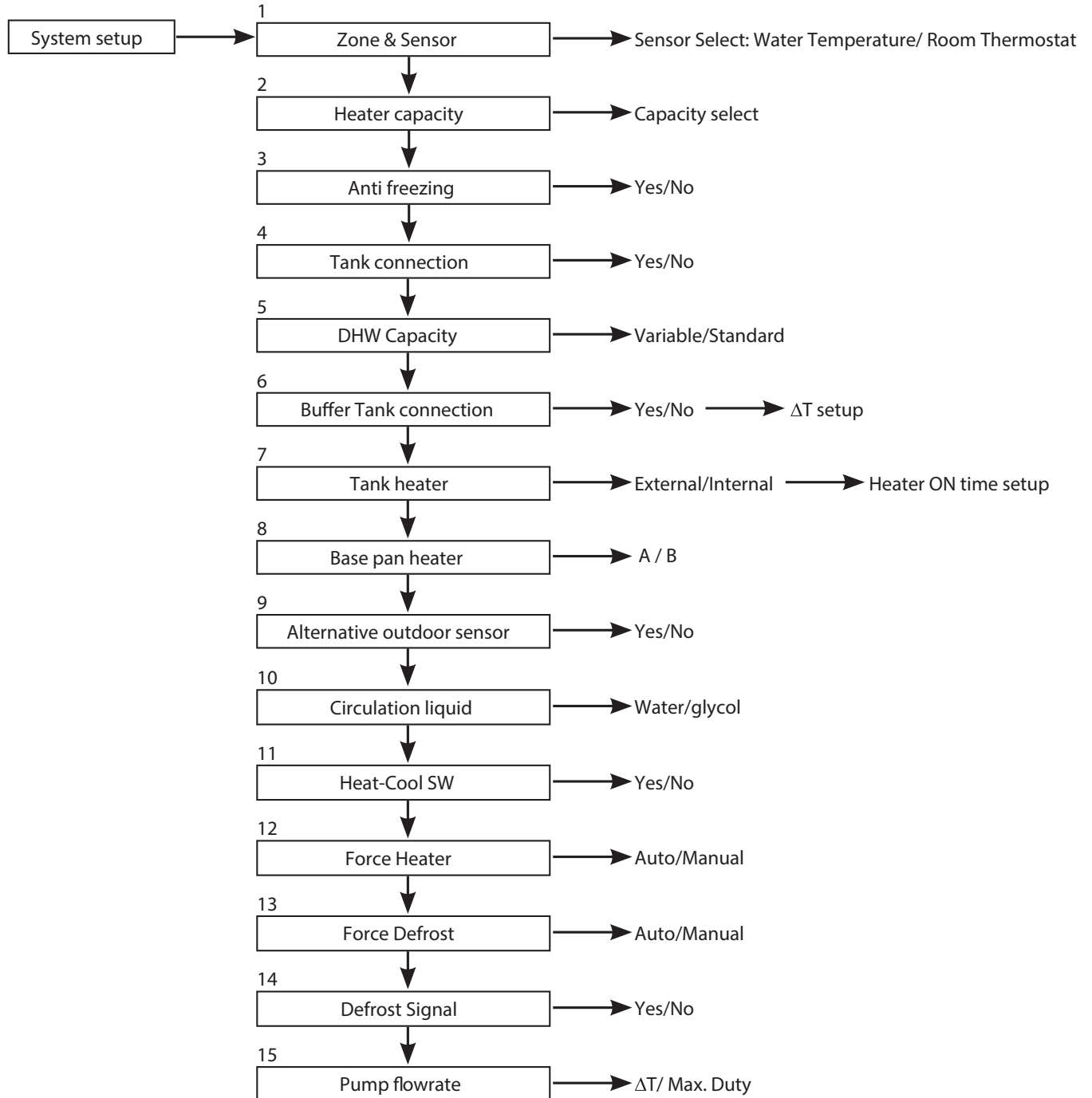

9 Installation

Operation setup

Figure 9-25 Control pad flowchart continued

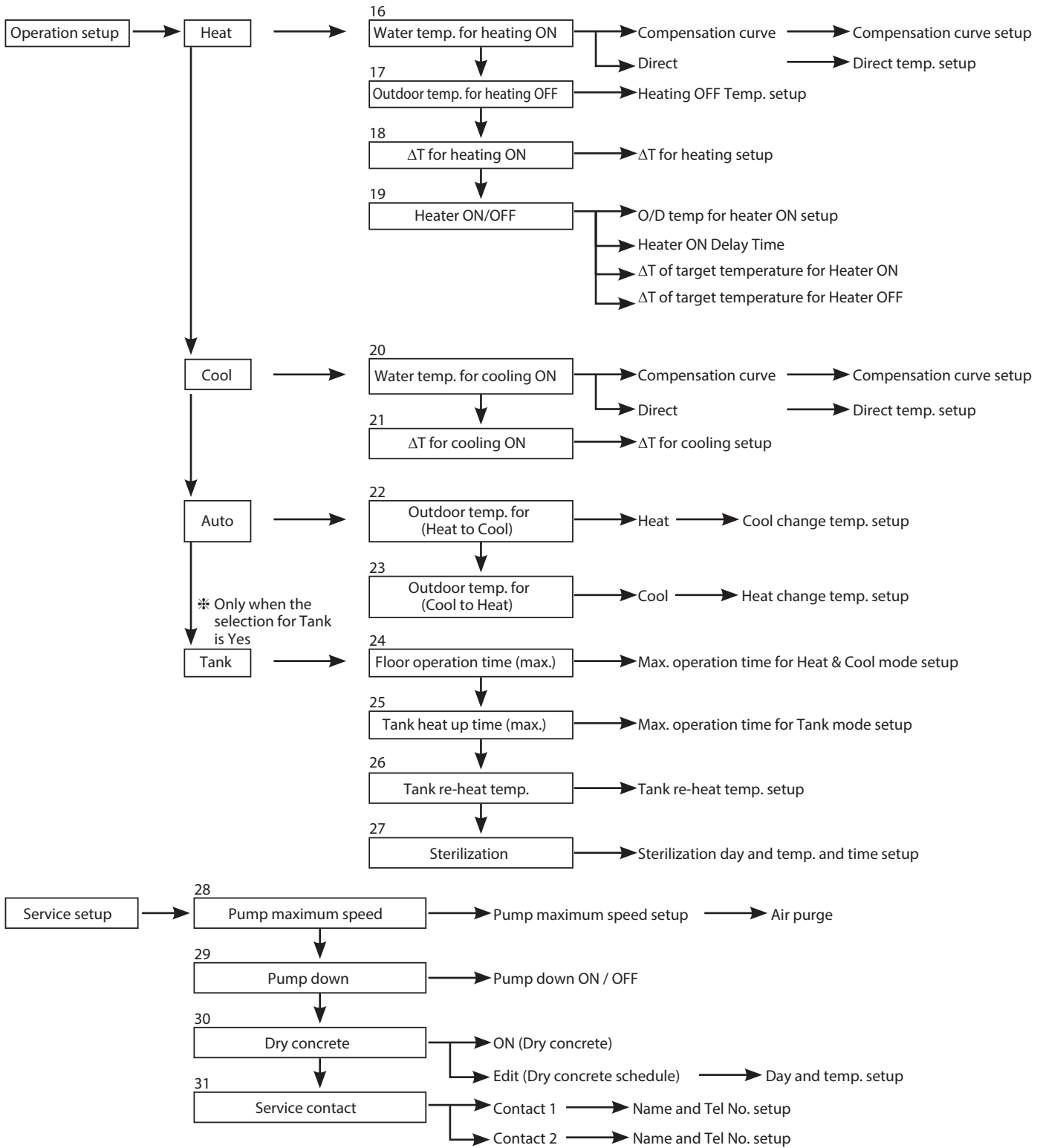

9 Installation

System setup

Figure 9-26 Control pad settings

<div style="border: 1px solid black; padding: 2px; display: inline-block;">1. Zone & Sensor</div>	<div style="border: 1px solid black; padding: 2px; display: inline-block;">Initial setting: Water temp.</div>	<p>Select sensor of room temperature control from the following 2 items</p> <ol style="list-style-type: none"> 1 Water temperature (Circulation water temperature) 2 Room thermostat (Internal or External) 	<table border="1" style="width: 100%; border-collapse: collapse;"> <tr> <td style="font-size: small;">System setup</td> <td style="text-align: right; font-size: small;">12:00am, Mon</td> </tr> <tr> <td style="background-color: #f0f0f0;">Zone & Sensor</td> <td></td> </tr> <tr> <td>Heater capacity</td> <td></td> </tr> <tr> <td>Anti freezing</td> <td></td> </tr> <tr> <td style="text-align: center;">⬇ Select</td> <td style="text-align: right;">[↵] Confirm</td> </tr> </table>	System setup	12:00am, Mon	Zone & Sensor		Heater capacity		Anti freezing		⬇ Select	[↵] Confirm		
System setup	12:00am, Mon														
Zone & Sensor															
Heater capacity															
Anti freezing															
⬇ Select	[↵] Confirm														
<div style="border: 1px solid black; padding: 2px; display: inline-block;">2. Heater capacity</div>	<div style="border: 1px solid black; padding: 2px; display: inline-block;">Initial setting: 6kW</div>	<p>Set the selectable heater capacity.</p>	<table border="1" style="width: 100%; border-collapse: collapse;"> <tr> <td style="font-size: small;">System setup</td> <td style="text-align: right; font-size: small;">12:00am, Mon</td> </tr> <tr> <td style="background-color: #f0f0f0;">Zone & Sensor</td> <td></td> </tr> <tr> <td style="background-color: #f0f0f0;">Heater capacity</td> <td></td> </tr> <tr> <td>Anti freezing</td> <td></td> </tr> <tr> <td style="text-align: center;">⬇ Select</td> <td style="text-align: right;">[↵] Confirm</td> </tr> </table>	System setup	12:00am, Mon	Zone & Sensor		Heater capacity		Anti freezing		⬇ Select	[↵] Confirm		
System setup	12:00am, Mon														
Zone & Sensor															
Heater capacity															
Anti freezing															
⬇ Select	[↵] Confirm														
<div style="border: 1px solid black; padding: 2px; display: inline-block;">3. Anti freezing</div>	<div style="border: 1px solid black; padding: 2px; display: inline-block;">Initial setting: Yes</div>	<p>Operate anti-freezing of water circulation circuit. If select Yes, when the water temperature is reaching its freezing temperature, the circulation pump will start up. If the water temperature does not reach the pump stop temperature, back-up heater will be activated.</p> <p>(NOTE) If set No, when the water temperature is reaching its freezing temperature or below 32°F, the water circulation circuit may freeze and cause malfunction.</p>	<table border="1" style="width: 100%; border-collapse: collapse;"> <tr> <td style="font-size: small;">System setup</td> <td style="text-align: right; font-size: small;">12:00am, Mon</td> </tr> <tr> <td style="background-color: #f0f0f0;">Zone & Sensor</td> <td></td> </tr> <tr> <td style="background-color: #f0f0f0;">Heater capacity</td> <td></td> </tr> <tr> <td style="background-color: #f0f0f0;">Anti freezing</td> <td></td> </tr> <tr> <td style="text-align: center;">⬇ Select</td> <td style="text-align: right;">[↵] Confirm</td> </tr> </table>	System setup	12:00am, Mon	Zone & Sensor		Heater capacity		Anti freezing		⬇ Select	[↵] Confirm		
System setup	12:00am, Mon														
Zone & Sensor															
Heater capacity															
Anti freezing															
⬇ Select	[↵] Confirm														
<div style="border: 1px solid black; padding: 2px; display: inline-block;">4. Tank connection</div>	<div style="border: 1px solid black; padding: 2px; display: inline-block;">Initial setting: No</div>	<p>Select whether it is connected to hot water tank or not. If set Yes, it becomes setting that uses hot water function. Hot water temperature of tank can be set from main screen.</p>	<table border="1" style="width: 100%; border-collapse: collapse;"> <tr> <td style="font-size: small;">System setup</td> <td style="text-align: right; font-size: small;">12:00am, Mon</td> </tr> <tr> <td style="background-color: #f0f0f0;">Zone & Sensor</td> <td></td> </tr> <tr> <td style="background-color: #f0f0f0;">Heater capacity</td> <td></td> </tr> <tr> <td style="background-color: #f0f0f0;">Anti freezing</td> <td></td> </tr> <tr> <td style="background-color: #f0f0f0;">Tank connection</td> <td></td> </tr> <tr> <td style="text-align: center;">⬇ Select</td> <td style="text-align: right;">[↵] Confirm</td> </tr> </table>	System setup	12:00am, Mon	Zone & Sensor		Heater capacity		Anti freezing		Tank connection		⬇ Select	[↵] Confirm
System setup	12:00am, Mon														
Zone & Sensor															
Heater capacity															
Anti freezing															
Tank connection															
⬇ Select	[↵] Confirm														

9 Installation

Figure 9-26 Control pad settings, continued

<div style="border: 1px solid black; display: inline-block; padding: 2px 5px; margin-right: 10px;">5. DHW Capacity</div> <div style="border: 1px solid black; display: inline-block; padding: 2px 5px;">Initial setting: Variable</div>	<table border="1" style="width: 100%; border-collapse: collapse;"> <tr><td style="text-align: left;">System setup</td><td style="text-align: right;">12:00am, Mon</td></tr> <tr><td colspan="2">Heater capacity</td></tr> <tr><td colspan="2">Anti freezing</td></tr> <tr><td colspan="2">Tank connection</td></tr> <tr style="background-color: #f0f0f0;"><td colspan="2">DHW Capacity</td></tr> <tr><td style="text-align: left;">▲ Select</td><td style="text-align: right;">[↵] Confirm</td></tr> </table>	System setup	12:00am, Mon	Heater capacity		Anti freezing		Tank connection		DHW Capacity		▲ Select	[↵] Confirm
System setup	12:00am, Mon												
Heater capacity													
Anti freezing													
Tank connection													
DHW Capacity													
▲ Select	[↵] Confirm												
<p>Variable DHW capacity setting normally run with efficient heating which is energy saving heating. But while hot water usage high and tank water temperature low, variable DHW mode will run with fast heat up which heat up the tank with high heating capacity. If standard DHW capacity setting is selected, heat pump run with heating rated capacity at tank heat up operation.</p>													

<div style="border: 1px solid black; display: inline-block; padding: 2px 5px; margin-right: 10px;">6. Buffer Tank connection</div> <div style="border: 1px solid black; display: inline-block; padding: 2px 5px;">Initial setting: No</div>	<table border="1" style="width: 100%; border-collapse: collapse;"> <tr><td style="text-align: left;">System setup</td><td style="text-align: right;">12:00am, Mon</td></tr> <tr><td colspan="2">Anti freezing</td></tr> <tr><td colspan="2">Tank connection</td></tr> <tr><td colspan="2">DHW Capacity</td></tr> <tr style="background-color: #f0f0f0;"><td colspan="2">Buffer tank connection</td></tr> <tr><td style="text-align: left;">▲ Select</td><td style="text-align: right;">[↵] Confirm</td></tr> </table>	System setup	12:00am, Mon	Anti freezing		Tank connection		DHW Capacity		Buffer tank connection		▲ Select	[↵] Confirm
System setup	12:00am, Mon												
Anti freezing													
Tank connection													
DHW Capacity													
Buffer tank connection													
▲ Select	[↵] Confirm												
<p>Select whether it is connected to buffer tank or not. If buffer tank is used, please set Yes. Connect buffer tank thermistor and set, ΔT (ΔT is used to increase primary side temp against secondary side target temp). If the buffer tank capacity is not so large, please set larger value for ΔT.</p>													

<div style="border: 1px solid black; display: inline-block; padding: 2px 5px; margin-right: 10px;">7. Tank heater</div> <div style="border: 1px solid black; display: inline-block; padding: 2px 5px;">Initial setting: Internal</div>	<table border="1" style="width: 100%; border-collapse: collapse;"> <tr><td style="text-align: left;">System setup</td><td style="text-align: right;">12:00am, Mon</td></tr> <tr><td colspan="2">Tank connection</td></tr> <tr><td colspan="2">DHW Capacity</td></tr> <tr><td colspan="2">Buffer tank connection</td></tr> <tr style="background-color: #f0f0f0;"><td colspan="2">Tank heater</td></tr> <tr><td style="text-align: left;">▲ Select</td><td style="text-align: right;">[↵] Confirm</td></tr> </table>	System setup	12:00am, Mon	Tank connection		DHW Capacity		Buffer tank connection		Tank heater		▲ Select	[↵] Confirm
System setup	12:00am, Mon												
Tank connection													
DHW Capacity													
Buffer tank connection													
Tank heater													
▲ Select	[↵] Confirm												
<p>Select to use either built-in heater or external heater as heater for hot water tank. If heater is installed on tank, please select External.</p>													
<p>Please set "Tank heater" to "ON" in the "Function setup" from remote controller when using heater to raise the tank temperature.</p>													
<p>External A setting which is using booster heater installed on DHW tank to re-heat the tank. The permissible heater capacity is 3kW and below. The operation to re-heat the tank with heater is as below. In addition, be sure to set suitable "Tank heater: ON time"</p>	<p>Internal A setting which is using backup heater of Mono bloc to re-heat the tank. The operation to re-heat the tank with heater is as below.</p>												
<div style="border: 1px solid black; display: inline-block; padding: 2px 5px; margin-bottom: 5px;">For 149°F setting</div> <p style="font-size: small;">*This value is an example and for reference only. Real values may differ.</p>	<div style="border: 1px solid black; display: inline-block; padding: 2px 5px; margin-bottom: 5px;">For 149°F setting</div> <p style="font-size: small;">*This value is an example and for reference only. Real values may differ.</p>												
<p>HP Booster heater Pump</p>	<p>HP Backup heater Pump</p>												

<div style="border: 1px solid black; display: inline-block; padding: 2px 5px; margin-right: 10px;">8. Base pan heater</div> <div style="border: 1px solid black; display: inline-block; padding: 2px 5px;">Initial setting: A</div>	<table border="1" style="width: 100%; border-collapse: collapse;"> <tr><td style="text-align: left;">System setup</td><td style="text-align: right;">12:00am, Mon</td></tr> <tr><td colspan="2">DHW Capacity</td></tr> <tr><td colspan="2">Buffer tank connection</td></tr> <tr><td colspan="2">Tank heater</td></tr> <tr style="background-color: #f0f0f0;"><td colspan="2">Base pan heater</td></tr> <tr><td style="text-align: left;">▲ Select</td><td style="text-align: right;">[↵] Confirm</td></tr> </table>	System setup	12:00am, Mon	DHW Capacity		Buffer tank connection		Tank heater		Base pan heater		▲ Select	[↵] Confirm
System setup	12:00am, Mon												
DHW Capacity													
Buffer tank connection													
Tank heater													
Base pan heater													
▲ Select	[↵] Confirm												
<p>A: Turn on Heater when heating with defrost operation only B: Turn on Heater at heating</p>													

<div style="border: 1px solid black; display: inline-block; padding: 2px 5px; margin-right: 10px;">9. Alternative outdoor sensor</div> <div style="border: 1px solid black; display: inline-block; padding: 2px 5px;">Initial setting: No</div>	<table border="1" style="width: 100%; border-collapse: collapse;"> <tr><td style="text-align: left;">System setup</td><td style="text-align: right;">12:00am, Mon</td></tr> <tr><td colspan="2">Buffer tank connection</td></tr> <tr><td colspan="2">Tank heater</td></tr> <tr><td colspan="2">Base pan heater</td></tr> <tr style="background-color: #f0f0f0;"><td colspan="2">Alternative outdoor sensor</td></tr> <tr><td style="text-align: left;">▲ Select</td><td style="text-align: right;">[↵] Confirm</td></tr> </table>	System setup	12:00am, Mon	Buffer tank connection		Tank heater		Base pan heater		Alternative outdoor sensor		▲ Select	[↵] Confirm
System setup	12:00am, Mon												
Buffer tank connection													
Tank heater													
Base pan heater													
Alternative outdoor sensor													
▲ Select	[↵] Confirm												
<p>Set Yes if outdoor sensor is installed. Controlled by optional outdoor sensor without reading the outdoor sensor of heat pump unit.</p>													

9 Installation

Figure 9-26 Control pad settings, continued

10. BackupBoiler connection

Initial setting: No

Set if heat pump linked with boiler operation.
 Connect the start signal of the boiler in boiler contact terminal (main PCB).
 Set Backup Boiler connection to YES.
 After that, please begin setting according to remote controller instruction.
 Boiler icon will be displayed on remote controller top screen.

System setup	12:00am, Mon
Tank heater	
Base pan heater	
Alternative outdoor sensor	
Backup Boiler	
Select	[←] Confirm

There are 3 different modes in the boiler operation. Movement of each modes are shown below.

- 1 Alternative (switch to boiler operation when drops below setting temperature)
- 2 Parallel (allow boiler operation when drops below setting temperature)
- 3 Advanced Parallel (able to slightly delay boiler operation time of parallel operation)

When the boiler operation is "ON", "boiler contact" is "ON", " _ " (underscore) will be displayed below the boiler icon.
 Please set target temperature of boiler to be the same as heat pump temperature.
 When boiler temperature is higher than heat pump temperature, zone temperature cannot be achieved if mixing valve is not installed.
 This product only allows one signal to control the boiler operation. Operation setting of boiler shall be responsible by installer.

Alternative mode

Parallel mode

Advanced Parallel mode

For heating

For DHW tank

AND

Although heat pump operates but water temperature does not reach this temperature for more than 30 mins (setting from remote controller)

Boiler temp. ON = Setting 17°F (setting from remote controller)
 Boiler temp. OFF = Setting 28°F (setting from remote controller)

AND

If actual tank temp. does not achieve the setting temp. within 30min (setting from remote controller), the boiler turn ON

When tank temp. is achieved, both operations stop

In Advanced Parallel mode, setting for both heating and tank can be made simultaneously. During operation of "Heating/Tank" mode, when each time the mode is switched, the boiler output will be reset to OFF. Please have good understanding on the boiler control characteristic in order to select the optimal setting for the system.

9 Installation

Figure 9-26 Control pad settings, continued

<p>11. Circulation Liquid Initial setting: Water</p> <p>Set circulation of heating water.</p> <p>There are 2 types of settings, water and glycol mixture.</p> <p>(NOTE) Please set glycol when using anti-freeze liquid. It may cause error if setting is wrong.</p>	<table border="1"> <tr><td>System setup</td><td>12:00am,Mon</td></tr> <tr><td>Base pan heater</td><td></td></tr> <tr><td>Alternate outdoor sensor</td><td></td></tr> <tr><td>Backup Boiler</td><td></td></tr> <tr><td>Circulation liquid</td><td></td></tr> <tr><td>▲ Select</td><td>[↵] Confirm</td></tr> </table>	System setup	12:00am,Mon	Base pan heater		Alternate outdoor sensor		Backup Boiler		Circulation liquid		▲ Select	[↵] Confirm
System setup	12:00am,Mon												
Base pan heater													
Alternate outdoor sensor													
Backup Boiler													
Circulation liquid													
▲ Select	[↵] Confirm												
<p>12. Heat-Cool SW Initial setting: Disable</p> <p>Able to switch (fix) heating & cooling by external switch.</p> <p>(Open) : Fix at Heating (Heating +DHW) (Short) : Fix at Cooling (Cooling +DHW)</p> <p>Timer function cannot be used. Cannot use Auto mode.</p>	<table border="1"> <tr><td>System setup</td><td>12:00am,Mon</td></tr> <tr><td>Alternative outdoor sensor</td><td></td></tr> <tr><td>Backup Boiler</td><td></td></tr> <tr><td>Circulation liquid</td><td></td></tr> <tr><td>Heat-Cool SW</td><td></td></tr> <tr><td>▲ Select</td><td>[↵] Confirm</td></tr> </table>	System setup	12:00am,Mon	Alternative outdoor sensor		Backup Boiler		Circulation liquid		Heat-Cool SW		▲ Select	[↵] Confirm
System setup	12:00am,Mon												
Alternative outdoor sensor													
Backup Boiler													
Circulation liquid													
Heat-Cool SW													
▲ Select	[↵] Confirm												
<p>13. Force Heater Initial setting: Manual</p> <p>Under manual mode, user can turn on force heater through quick menu.</p> <p>If selection is 'auto', force heater mode will turn automatically if pop up error happen during operation.</p> <p>Force heater will operate follow the latest mode selection, mode selection is disable under force heater operation.</p> <p>Heater source will ON during force heater mode.</p>	<table border="1"> <tr><td>System setup</td><td>12:00am,Mon</td></tr> <tr><td>External compressor SW</td><td></td></tr> <tr><td>Circulation liquid</td><td></td></tr> <tr><td>Heat-Cool SW</td><td></td></tr> <tr><td>Force Heater</td><td></td></tr> <tr><td>▲ Select</td><td>[↵] Confirm</td></tr> </table>	System setup	12:00am,Mon	External compressor SW		Circulation liquid		Heat-Cool SW		Force Heater		▲ Select	[↵] Confirm
System setup	12:00am,Mon												
External compressor SW													
Circulation liquid													
Heat-Cool SW													
Force Heater													
▲ Select	[↵] Confirm												
<p>14. Force Defrost Initial setting: Manual</p> <p>Under manual code, user can turn on force defrost through quick menu.</p> <p>If selection is 'auto', outdoor unit will run defrost operation once if heat pump have long hour of heating without any defrost operation before at low ambient condition. (Even auto is selected, user still can turn on force defrost through quick menu)</p>	<table border="1"> <tr><td>System setup</td><td>12:00am,Mon</td></tr> <tr><td>Circulation liquid</td><td></td></tr> <tr><td>Heat-Cool SW</td><td></td></tr> <tr><td>Force heater</td><td></td></tr> <tr><td>Force defrost</td><td></td></tr> <tr><td>▲ Select</td><td>[↵] Confirm</td></tr> </table>	System setup	12:00am,Mon	Circulation liquid		Heat-Cool SW		Force heater		Force defrost		▲ Select	[↵] Confirm
System setup	12:00am,Mon												
Circulation liquid													
Heat-Cool SW													
Force heater													
Force defrost													
▲ Select	[↵] Confirm												
<p>15. Defrost signal Initial setting: No</p> <p>Defrost signal sharing same terminal as boiler contact in main board. When defrost signal set to YES, boiler connection reset to NO. Only one function can be set between defrost signal and bivalent.</p> <p>When defrost signal set to YES, during defrost operation is running at outdoor unit defrost signal contact turn ON. Defrost signal contact turn OFF after defrost operation end. (Purpose of this contact output is to stop indoor fan coil or water pump during defrost operation).</p>	<table border="1"> <tr><td>System setup</td><td>12:00am,Mon</td></tr> <tr><td>Heat-Cool SW</td><td></td></tr> <tr><td>Force heater</td><td></td></tr> <tr><td>Force defrost</td><td></td></tr> <tr><td>Defrost signal</td><td></td></tr> <tr><td>▲ Select</td><td>[↵] Confirm</td></tr> </table>	System setup	12:00am,Mon	Heat-Cool SW		Force heater		Force defrost		Defrost signal		▲ Select	[↵] Confirm
System setup	12:00am,Mon												
Heat-Cool SW													
Force heater													
Force defrost													
Defrost signal													
▲ Select	[↵] Confirm												
<p>16. Pump flowrate Initial setting: ΔT</p> <p>If pump flowrate setting is ΔT, unit adjust pump duty to get different of water inlet and outlet base on setting on * ΔT for heating ON and * ΔT for cooling ON in operation setup menu during room side operation.</p> <p>If pump flowrate setting is set to Max. duty, unit will set the pump duty to the set duty at *Pump maximum speed in service setup menu during room side operation.</p>	<table border="1"> <tr><td>System setup</td><td>12:00am,Mon</td></tr> <tr><td>Force heater</td><td></td></tr> <tr><td>Force defrost</td><td></td></tr> <tr><td>Defrost signal</td><td></td></tr> <tr><td>Pump flowrate</td><td></td></tr> <tr><td>▲ Select</td><td>[↵] Confirm</td></tr> </table>	System setup	12:00am,Mon	Force heater		Force defrost		Defrost signal		Pump flowrate		▲ Select	[↵] Confirm
System setup	12:00am,Mon												
Force heater													
Force defrost													
Defrost signal													
Pump flowrate													
▲ Select	[↵] Confirm												

9 Installation

Figure 9-26 Control pad settings, continued

17. Water temp. for heating ON

Initial setting: compensation curve

Set target water temperature to operate heating operation.
 Compensation curve: Target water temperature change in conjunction with outdoor ambient temperature change.
 Direct: Set direct circulation water temperature.
 Regardless of the above setting, the water temperature will be limited as follows.

Outdoor temperature	Maximum water temperature limit
-4°F	131°F
5 ~ 32°F	140°F
41~ 68°F	149°F
77~ 95°F	140°F

Hot water temperature: 131°F, 95°F
 Outdoor temperature: 23°F, 59°F
 Decide temperature of 4 points as shown in diagram
 Outdoor temperature compensation curve

18. Outdoor temp. for heating OFF

Initial setting: 75°F

Set outdoor temp to stop heating.
 Setting range is 41°F ~ 95°F

ON
OFF
75°F

19. ΔT for heating ON

Initial setting: 9°F

Set temp difference between out temp & return temp of circulating water of Heating operation.
 When temp gap is enlarged, it is energy saving but less comfort. When the gap gets smaller, energy saving effect gets worse but it is more comfortable.
 Setting range is 2°F ~ 27°F

Out
Return
Out — Return = 2°F ~ 27°F

20. Heater ON/OFF

a. Outdoor temp. for heater ON

Initial setting: 32°F

Set outdoor temp when back-up heater starts to operate.
 Setting range is -4°F ~ 59°F
 User shall set whether to use or not to use heater.

ON
OFF
32°F

b. Heater ON delay time

Initial setting: 30 minutes

Set delay time from compressor ON for heater to turn ON if not achieve water set temperature.
 Setting range is 10 minutes ~ 60 minutes

Heater ON
Compressor ON
0 : 30

c. Heater ON: ΔT of target Temp

Initial setting: -7°F

Set water temperature for heater to turn on at heat mode.
 Setting range is -18°F ~ -4°F

Water Set Temp.
Heater OFF
Heater ON
24.8°F
-4°F

d. Heater OFF: ΔT of target Temp

Initial setting: -4°F

Set water temperature for heater to turn off at heat mode.
 Setting range is -6°F ~ 0°F

9 Installation

Figure 9-26 Control pad settings, continued

<p>21. Water temp. for cooling ON</p>	<p>Initial setting: Compensation curve</p>	<p>68°F 41°F 68°F 86°F compensation curve</p>
<p>Set target water temperature to operate cooling operation. Compensation curve: Target water temperature change in conjunction with outdoor ambient temperature change. Direct: Set direct circulation water temperature.</p>		
<p>22. ΔT for cooling ON</p>	<p>Initial setting: 9°F</p>	<p>Out Return Return — Out = 2°F ~ 27°F</p>
<p>Set temp difference between out temp & return temp of circulating water of Cooling operation. When temp gap is enlarged, it is energy saving but less comfort. When the gap gets smaller, energy saving effect gets worse but it is more comfortable. Setting range is 2°F ~ 27°F</p>		
<p>23. Outdoor temp. for (Heat to Cool)</p>	<p>Initial setting: 59°F</p>	<p>Heat Outdoor temp. rising Cool ◀ 59°F ▶</p>
<p>Set outdoor temp that switches from heating to cooling by Auto setting. Setting range is 41°F ~ 77°F Timing of judgement is every 1 hour</p>		
<p>24. Outdoor temp. for (Cool to Heat)</p>	<p>Initial setting: 50°F</p>	<p>Heat Outdoor temp. dropping Cool ◀ 50°F ▶</p>
<p>Set outdoor temp that switches from Cooling to Heating by Auto setting. Setting range is 41°F ~ 77°F Timing of judgement is every 1 hour</p>		
<p>25. Floor operation time (max.)</p>	<p>Initial setting: 8h</p>	<p>Heat 30min ~ 10h Tank</p>
<p>Set max operating hours of heating. When max operation time is shortened, it can boil the tank more frequently. It is a function for Heating + Tank operation.</p>		
<p>26. Tank heat up time (max.)</p>	<p>Initial setting: 60min</p>	<p>Heat Tank 5min ~ 4h</p>
<p>Set max boiling hours of tank. When max boiling hours are shortened, it immediately returns to Heating operation, but it may not fully boil the tank.</p>		
<p>27. Tank re-heat temp.</p>	<p>Initial setting: -14°F</p>	<p>-21°F ~ -4°F</p>
<p>Set temp to perform reboil of tank water. Setting range is -21°F ~ -4°F</p>		
<p>28. Sterilization</p>	<p>Initial setting: 149°F 10min</p>	<p>② ① ③</p>
<p>Set timer to perform sterilization. ① Set operating day & time. (Weekly timer format) ② Sterilization temp (131°F ~ 167°F * If use back-up heater, it is 149°F) ③ Operation time (Time to run sterilization when it reached setting temp 5min ~ 60min) User shall set whether to use or not to use sterilization mode.</p>		

9 Installation

Figure 9-26 Control pad settings, continued

29. Pump maximum speed

Normally setting is not necessary.
Please adjust when need to reduce the pump sound etc.
Besides that, it has Air Purge function.
When *Pump flow setting is Max. Duty, this duty set is the fix pump duty run during room side operation.

Service setup		12:00am, Mon
Flow rate	Max. Duty	Operation
0.00 gal/min	0x00	▲ Air Purge
◀ Select		

30. Pump down

Operate pump down operation

Service setup		12:00am, Mon
Pump down:		
ON		
[↵] Confirm		

Pump down operation
in progress!

[⏻] OFF

31. Dry concrete

Operate concrete curing operation.
Select Edit, set temp for every stage (1~99 1 is for 1 day).
Setting range is 77~131°F
When it is turned ON, dry concrete starts.

86°F	95°F	104°F	113°F	104°F	95°F
①	②	③	④	⑤	⑥

→ Stage

32. Service contact

Able to set name & tel no. of contact person when there is breakdown etc. or client has trouble. (2 items)

Service setup		12:00am, Mon
Service contact:		
Contact 1		
Contact 2		
▲ Select		[↵] Confirm

Contact-1: Bryan Adams	
ABC/ abc	0-9/ Other
A B C D E F G H I J K L M N O P Q R	
S T U V W X Y Z a b c d e f g h i	
j k l m n o p q r s t u v w x y z	
▼ Select	[↵] Enter

71

10 Servicing Centrus using R32

About R32 Refrigerant

For refrigerants such as R410A, the refrigerant was collected after being replaced in order to prevent their dissipation into the air and to curb the impact of global warming, in the event they were released into the atmosphere. In the “4th Environmental Basic Plan,” an 80% reduction of greenhouse gas emissions by 2050 is required; due to this requirement, further reduction in the emission of high global warming potential gases, such as CFCs, is required. Therefore, converting from air conditioning refrigerants with greater greenhouse effects to ones with lesser greenhouse effects, even if they are released into the atmosphere, has become our responsibility.

It would be best if there were a refrigerant that had a lesser impact on global warming, but would still ensure good energy efficiency and performance, and were safe; however, there is no such refrigerant that satisfies all of these conditions. As a result, we have been considering the practical usage, within the safety framework, of R32 refrigerant, which decays relatively quickly in the atmosphere, and has a lesser effect on global warming, but is slightly flammable.

In 2004, due to the revision of air conditioner safety standards by the International Electro-safety Commission (IEC), safety standards for air conditioners using slightly flammable refrigerant were issued. In 2010, the regulations of the American Society of Heating, Refrigerating and Air-Conditioning Engineers in the United States (ANSI/ASHRAE34) were issued, adopting the grades for refrigerants which are difficult to ignite due to their slow burning rates, and as a result cause less damage in cases of fire. The burning rate of R32 is lower by 4 inches / per second; safety standardization for various uses is now being processed.

Characteristics of R32 refrigerant

Chemical characteristics

R32 is one of the refrigerants used in R410A. It has almost no toxicity and is a chemically stable compound formed of hydrogen, carbon, and fluorine.

R32 has a short lifespan of 4 to 9 years if released into the atmosphere; therefore, it has lesser greenhouse gas effects but is slightly flammable because of the large proportion of hydrogen it contains.

Characteristics of pressure

As shown in Table 10-2, R32 does not have much difference in vapor pressure at the same refrigerant temperature compared to R410A. Compared to R22, R32 is greater by a factor of 1.6. Thus, just like with R410A, it is necessary to perform installation and service using high-pressure tools and components.

Table 10-1 Chemical Characteristic of R32, R410A and R22.

	R32	R410A	R22
Chemical Formula	CH2F2	CH2F2 / CHF2CF3	CHCLF2
Composition (mixture ratio wt. %)	Single composition	R32 / R125A (50 / 50 wt.%)	Single composition
Boiling Point (F)	-61.06	-60.7	-41.44
Pressure (physical) *1	455	445	281
Capacity (physical) *2	160	141	100
COP (physical) *3	95	91	100
Ozone Depletion Potential (ODP)	0	0	0.055
Global Warming Potential (GWP) *4	675	2090	1810
Flammability *5	Slightly flammable (A2L)	Nonflammable (A1)	Nonflammable (A1)
Toxicity	None	None	None

*1: Physical property at 122°F

*2: Relative value at 32/122°F, provided R22=100

*3: Te/Tc/SC/SH=41/122/5/0°F

*4: GWP=Global Warming Potential, each figure is based on “4th IPCC4 Report”

*5: Based on ANSI / ASHRAE Standard 34-2010

10 Servicing Centrus using R32

Table 10-2 Saturated vapor pressure comparison

Temperature	Refrigerant		
	R32 (PSI)	R410A (PSI)	R22 (PSI)
-4	43.5	43.5	20.3
32	102.9	101.5	58.0
68	198.7	195.8	117.5
104	345.2	336.5	207.4
140	556.9	540.9	337.9
149	622.2	604.8	377.1

Reference: Thermal properties table of Japan Society of Refrigerating and Air Conditioning Engineers (140, 149°F) NIST REFPROP V8.0 (-4 ~ 104°F)

Refrigerant piping installation

Required tools

R32 refrigerant air conditioners use the same parts as R410A air conditioners for two-way valves and three-way valves (diameters of service ports); thus, they are the same in terms of maintenance of the compressive strength, the size of pipe flaring, and the size of flare nuts as R410A. For refrigerant pipe installation and services, you can use tools for R410A.

However, mixing of refrigerants is not allowed. You must separate the cylinders when recovering refrigerants.

Table 10-3 Tools used for installation

Works	R32	R410A	R22
Flaring	Flaring tools for R410A (clutch type)		Flaring tools for R22 (clutch type)
Connecting pipes	Torque wrench (diameter 1/4, 3/8)		
	Torque wrenches (diameters 1/2, 5/8) *1		Torque wrenches (diameters 1/2, 5/8)
Manifold gauge charging hose	R32 & R410A Common (As of November 2013)		R22 Only
Air purging	Vacuum pump + Reducer / expander		Vacuum pump
Gas leakage test	Detection liquid or soap water, HFC detector		

*1. Nut diameters of 1/2, 5/8, the size of torque wrench common with R410A

Table 10-4 Tools used for servicing

Works	R32	R410A	R22
Adding refrigerant	Digital scale for refrigerant charging, refrigerant cylinders, cylinder adapters and packing *a		
Recovering refrigerant	Refrigerant recovery devices, refrigerant cylinders, manifold gauges, charging hoses *b		

*a. Use cylinder for each refrigerant, cylinder adapter and packing.

*b. Use a separate refrigerant recovery cylinder for each refrigerant (mixing refrigerants not allowed). Please be aware that there are some refrigerant collection devices that do not have self-certification.

10 Servicing Centrus using R32

Tools for R32 (common with R410A)

Flare sizing gauges

Use flare sizing gauges when you perform flaring with flaring tools (crutch type).

Figure 10-1 Flare sizing gauges



Flaring tools (clutch type)

Flaring tools have larger holes and clump bars, and have stronger springs inside to ensure solid flaring torques. These flaring tools can also be used for R22.

Figure 10-2 Flaring tools (clutch type)



Torque wrenches (diameters 1/2, 5/8)

In order to increase the compressive strength, the diameters of wrenches change depending on the size of the flare nut.

Figure 10-3 Torque wrenches

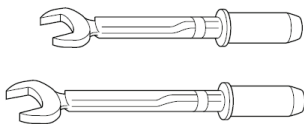

Table 10-5 Differences in torque wrenches

	R32 (common R410A)	R22
1/2 (diameter x torque)	1 in x 40.5 lb-ft	15/16 in x 40.5 lb-ft
5/8 (diameter x torque)	1-1/8 in x 47.9 lb-ft	1-1/16 in x 47.9 lb-ft

Manifold gauges

R22 gauges cannot be used because of the high pressures. Each port of the manifold are shaped differently in order to prevent adding the wrong refrigerant.

*However, the shape of the ports for R410A and R32 is the same; therefore, attention needs to be paid to ensure that the wrong refrigerant is not used.

Table 10-6 Differences in high/low pressure gauges

	R32 (common R410A)	R22
High pressure gauges (red)	-14 ~ 753.8 PSI	-14 ~ 497.8 PSI
Low pressure gauges (blue)	-14 ~ 540.5 PSI	-14 ~ 241.8 PSI

Table 10-7 Difference in manifold port sizes

	R32 (common R410A)	R22
Port sizes	1/2 UNF20	7/16 UNF20

Charging hoses

The pressure resistance of charge hoses is increased. At the same time, the material is changed to HFC resistant, and the size of each manifold adapter, as well as the port size of manifold gauge itself, is changed. Additionally, some hoses have anti-gas-pressure-backflow valves placed near the adapters.

Figure 10-4 Manifold gauges / charging hoses



10 Servicing Centrus using R32

Table 10-8 Difference in manifold port sizes

		R32 (common R410A)	R22
Pressure Resistance	Normal operating pressure	739.7 PSI	493.1 PSI
	Burst pressure	3974 PSI	2494.6 PSI
Material		HNBR rubber, internal nylon coating	NBR rubber

Vacuum pump and vacuum pump adapter

When using a vacuum pump, it is necessary to set a solenoid valve in order to prevent backflow of vacuum pump oil into the charging hoses. Use a vacuum pump with oil backflow prevention function, or use the vacuum pump with vacuum pump adapter. If vacuum pump oil (mineral oil based) mixes with R410A (R32), it may cause damage to the machine.

Figure 10-5 Vacuum pump

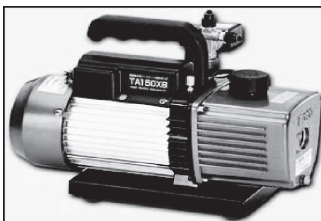

Figure 10-6 Vacuum pump adapter



Electronic HFC refrigerant gas leak detector

R32 refrigerant is often used for other mixed refrigerants (R410A, R404A, R407C, etc.). Therefore, the use of existing HFC detectors is possible, but in order to detect more accurately, we recommend using detectors specifically set and adjusted for R32 detection.

Figure 10-7 Electronic HFC refrigerant gas leak detector



Digital scale for refrigerant charging

R32 and R410A have high pressure level and their evaporation speed is high. Thus, if you recover the refrigerant using the cylinder charging method, the refrigerant evaporates within the weighing scale glass, which makes reading the scale difficult, rather than liquefying the refrigerant into the cylinder. (Charging cylinders for R22 have different pressure resistance, scale, and connection port size; therefore, they are not usable.) At the same time, the digital scale for refrigerant charging is strengthened by receiving the weight of the refrigerant cylinders with four pillars at the corners. The connection ports of charging hoses have two separate ports for R22 (7/16 UNF20) and R32/R410A (1/2 UNF20); therefore, they can be used for charging the existing refrigerants.

Figure 10-8 Digital scale for refrigerant charging

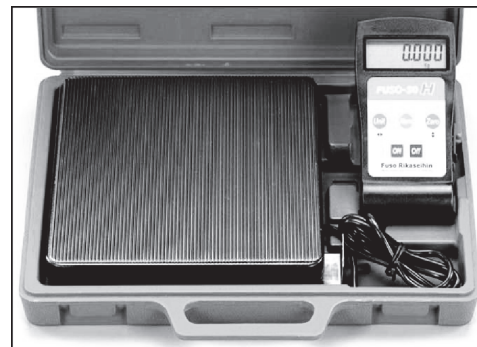

10 Servicing Centrus using R32

Refrigerant cylinders

Refrigerant cylinders for R410A are painted pink, while those for R32 are painted different colors that correspond to various international standards. R32 is a single refrigerant, so that charging with either liquid or gas is possible. Additional charging is also possible. (R410A is a mixed refrigerant, so only charging with liquid is possible).

Figure 10-9 Refrigerant cylinder



Connection ports on refrigerant cylinders and packaging

Charging ports that fit the charging hose connection port size (1/2 UNF20) are needed. At the same time, the packing must be made of HFC resistant materials.

Figure 10-10 Connection port

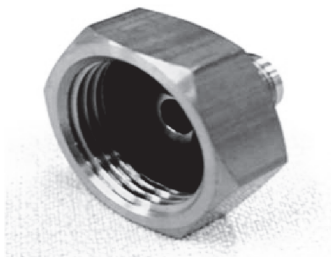

10 Servicing Centrus using R32

Table 10-9 Tools used for refrigerant piping installation and servicing

Tools for R410A	In common with R32	Possibility of use for R22
Pipe cutters, reamers or scrapers	○	○
Flaring tools (clutch type)	○	○
Torque wrenches (1/4, 3/8)	○	○
Torque wrenches (1/2, 5/8)	○	×
Manifold gauges / charging hoses	○	×
Vacuum pumps, vacuum pump adapters	○ Connection 5/16	○ Connection 1/4
Electronic gas leak detectors for HFC *1	○	△
Digital scale for refrigerant charging	○	○
HCF recovery devices (connection port 5/16) *2	○ Connection 5/16	○ Connection 1/4
Refrigerant cylinders (pressure resistant: FC3)	Same specs ×	×
Refrigerant cylinders (pink)	Other (different colors that might correspond to various international standards).	×
Refrigerant cylinder connection ports and packing	○	×
Allen wrench (5/32 in), electric knives	○	○

*1 Those detectors only for HCFC22 (R22), but not for HCF32 (R32) and HCF410A (R410A) cannot be for common use.

*2 Recovery devices that are self-certified for each HCF type can be used.

Knowledge of the use of tools in common for R410A & R32

R410A and R32 machines use different compressor oils. If unregulated compressor oil gets mixed in, it may cause damage to the machine function. Careful pump-down will ensure the recovery of compressor oil and will minimize the amount of oil remaining in the manifold gauge and charging hose. If you only perform the recovery of refrigerant and are not able to perform pump-down, you must dispose of the compressor oil in the charging hose.

Precaution when repairing refrigerant circuit

During brazing, open the two-way and three-way valves, and make sure the refrigerant is completely recovered, not leaving any refrigerant in the system. When making repairs outdoors, ensure there is no vaporized refrigerant is in the air, ensure good ventilation, and perform the brazing.

Adding incorrect refrigerant

Using incorrect refrigerant may result in customer complaints that the system is “not cooling” or “not heating” because each component (expansion valve, compressor, PCB) of the refrigeration circuit is specially adjusted for R32. At the same time, adding the incorrect refrigerant to the system will void the product warranty.

10 Servicing Centrus using R32

Procedures for new installation, relocation, repairing the refrigerant circuit system

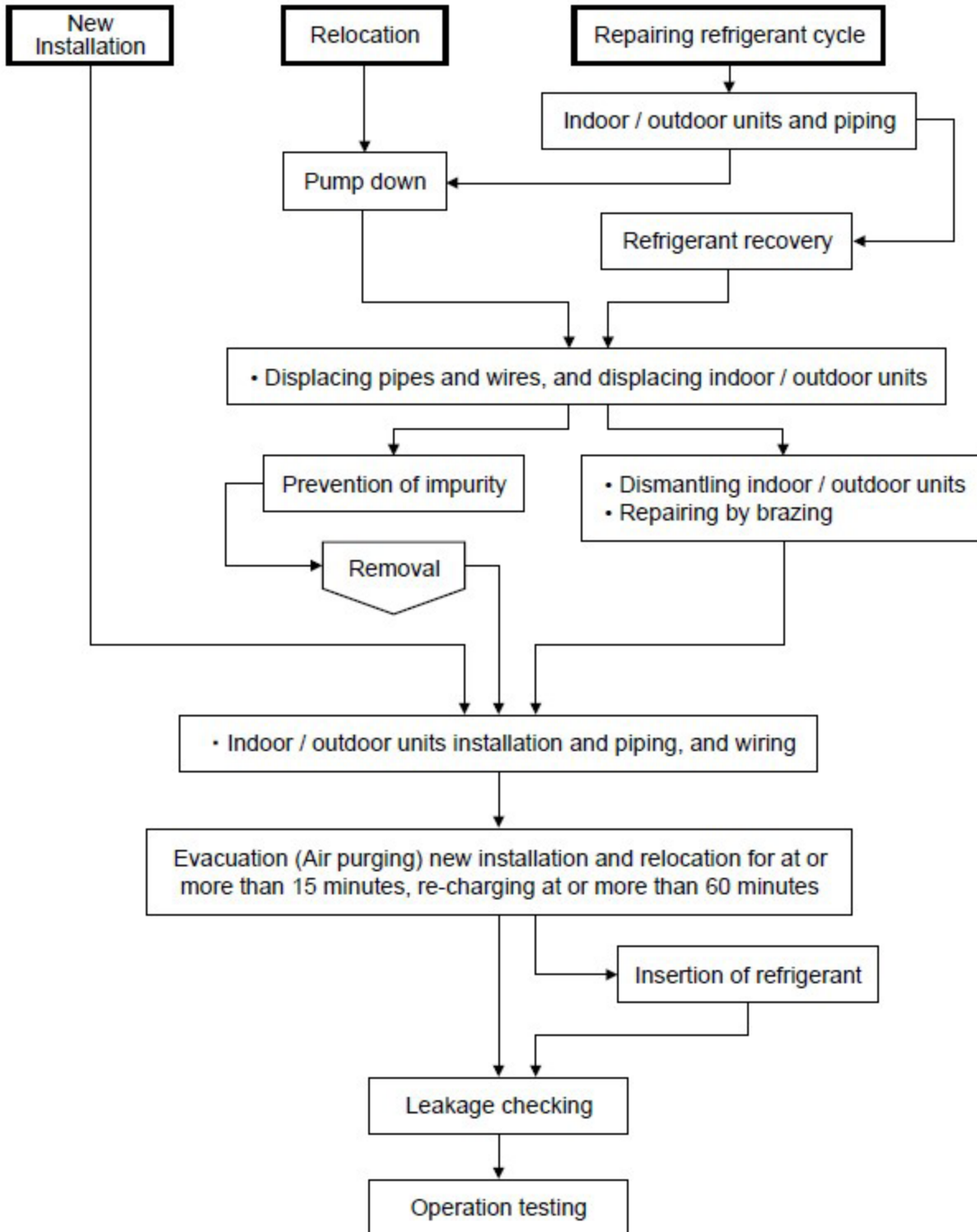

10 Servicing Centrus using R32

R32 piping installation

Pipe materials used and flaring

Copper pipes are used for refrigerant piping. Pipes that comply with JIS Regulations must be used. Room air conditioners that use R410A and R32 have higher pressure; thus, using pipes that comply with regulations is important. The pipe thickness is regulated by revised JIS B 8607 “Flaring and brazing fittings for refrigerant.” The pipe thickness for R410A, R32 is shown in the table.

Table 10-10 Pipe thickness

O and OL materials	Thickness (inches)			
	Diameter	R410A	R32	R22
	1/4	1/32		
	3/8	1/32		
	1/2	1/32		
	5/8	1/25		

CAUTION For connection piping, use copper phosphate seamless pipes (1220T) with a pipe thickness if 1/32 inch as regulated in “JIS H 3300.”

CAUTION There are pipes with a thickness of 1/38 inch available on the market. Do not use these pipes (1/32 inch thickness must be strictly adhered to).

CAUTION It is recommended that pipes with an oil adhesion of less than 0.0014 oz / 32.8 ft be used. At the same time, do not use pipes that have dents, are misshapen, or are discolored (especially inside).

Processing and connecting pipes

For refrigerant pipe installation, be certain moisture and dirt do not get into the pipes, and make sure there is no refrigerant leakage.

Procedure of flaring and precautions:

- a) Using a pipe cutter, cut the pipe slowly, being sure not to deform the pipe.
- b) Remove the burrs on the edge of pipe using a reamer or scraper. If the condition of pipe edge after the deburring is unsatisfactory or if burrs attach on the flaring, these conditions may cause refrigerant leakage. Turn the pipe end down and deburr carefully.
- c) Insert the flare nut.
- d) Ensure the cleanliness of clump bar and pipe, and perform flaring carefully.

Use the included flaring tools or flaring tools for R410A. Be aware that the sizes and dimensions of flaring are different for each flaring tool. If you use the included flaring tools, use a flaring gauge to measure the length of the flared part.

10 Servicing Centrus using R32

Installation, relocation, and service Air purge and gas leak test for new installation (using new refrigerant pipes) using vacuum pump.

For global environment protection, do not release CFCs into the atmosphere during installation work.

1. Connect the charging hose of the manifold gauge to the service port of the three-way valve (push insert pin).
2. Fully open the "Lo" handle on the manifold gauge and operate the vacuum pump. (If the needle on the low-pressure gauge reaches the vacuum immediately, check procedure again.)
3. Allow the vacuum to operate for 15 minutes or more, and make sure the low-pressure gauge reaches -30 inHg. When the vacuum operation is complete, fully open the "Lo" handle on the manifold gauge and stop the vacuum pump. Wait for 1 ~ 2 minutes. Then remove the connection side of the charging hose from the vacuum pump adapter after ensuring the needle on the manifold gauge does not move back.
4. Open the stem of the two-way valve 90° counterclockwise, and close the two-way valve after 10 seconds. Perform a gas leak test.
5. Remove the charge hose from the service port on the three-way valve. Carefully turn the stems of the two-way and three-way valves counterclockwise to open. Do not open the valves completely.
6. Tighten the service port cap with a torque wrench to 13.3 lb-ft. Tighten the caps of the two-way and three-way valves with a torque wrench to 13.3 lb-ft.
7. After tightening each cap, check for gas leakage around the cap.

Figure 10-11 Vacuum pump connection

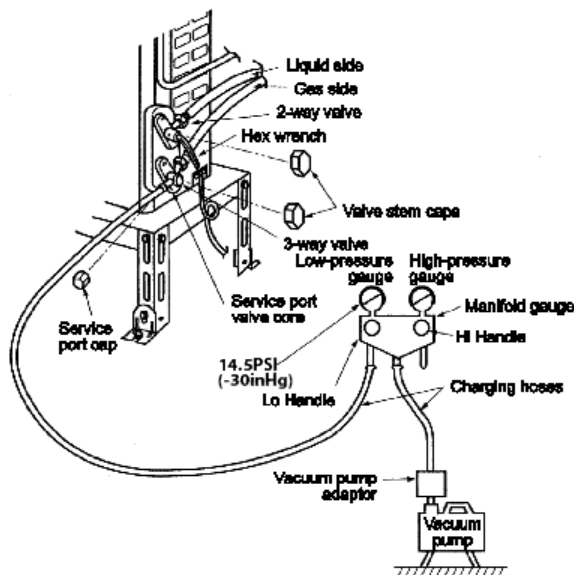

Process for refrigerant recovery

1. Connect the center charging hose of the manifold gauge to the inlet side of the recovery device.
2. Connect the valves on the discharge side of the recovery device and liquid side of refrigerant cylinder with the red hose (charging hose).
3. Connect the yellow float switch cable on the recovery device to the refrigerant cylinder.
4. Open the low pressure side valve of the manifold gauge.
5. Slightly loosen the charging hose on the inlet connecting side of the recovery device and purge the air.
6. Open the valve on the refrigerant cylinder and slightly loosen the charging hose on the discharge side of the recovery device. Purge the air. The recovery cylinder must be slightly pressurized.
7. Insert the electric plug of the recovery device into an electrical outlet. The fan operation will start.
8. Turn valves 1 and 2 of the recovery device to the pressure equalization point.
9. After a few seconds, turn the valves back to the original position.
10. Turn the switch on the recovery device to "ON." The compressor operation will start.
11. When the low pressure of manifold gauge is close to "0," close the low pressure side valve and turn the recovery device switch to "OFF."
12. Remove the center charging hose of the manifold gauge from the recovery device.

Figure 10-12 Refrigerant recovery

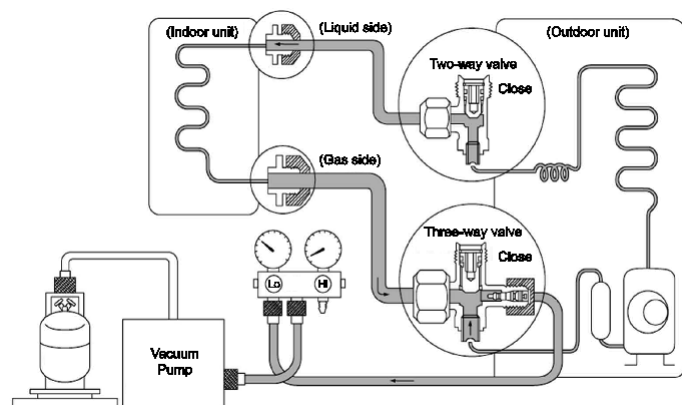

10 Servicing Centrus using R32

Relocation - Removing the air conditioning unit

Recovery of outdoor unit refrigerant by pumping down

Press "forced cooling button" (as a general rule, since 1998 the name of cooling test button has been changed, and this name is standardized within the air conditioning industry). You will then be able to start cooling operation in which the room temperature is low, and you can recover the refrigerant from the outdoor unit.

1. Check that the valve stems of the two-way and three-way valves are open by turning them counterclockwise. Remove the caps, and confirm the bars are fully open. Use a hex wrench (0.16 inches) to open and close the valves.
2. Press and hold the "Emergency Operation" button on the indoor units for five seconds and release. "Forced Cooling Operation" (for old models, press "forced cooling" button). Then operate the air conditioning unit for about 10 minutes.
3. Turn the stem of the two-way valve clockwise and close the valve.
4. After about 2 ~ 3 minutes, turn the stem of the three-way valve quickly clockwise, and stop the operation.
5. Attach and tighten the caps on the two-way and three-way valves with a torque wrench.

CAUTION

In the pump-down operation, stop the compressor before removing the refrigerant pipes. If you do not stop the compressor operation, if the valve is open and you remove the refrigerant pipes, air may be sucked into the system causing extremely high temperatures in the refrigerant circuit. This may result in rupture or injury.

6. Remove the connecting pipes (liquid side and gas side).

Removal of indoor and outdoor units

1. Remove the connecting pipes and wires between the indoor and outdoor units.
2. Attach capping flare nuts to the edges of the pipes connecting the indoor and outdoor units in order to prevent dust and moisture from getting into the pipes.
3. Remove the indoor and outdoor units.

Replacement of air conditioning units and evacuation (when reusing the existing pipes)

When replacing the air conditioning units, you can use the existing pipes, but it is recommended that flaring be performed again. If the unit is to be replaced, even if the unit is a new refrigerant air conditioner, if the refrigerant oil is different, it may cause problems. When reusing the existing refrigerant pipes, it is recommended that the pipes be evacuated as fully as possible because refrigerant oil may be adhered to the surface of the pipes. If the pipes are used without being evacuated, the remaining refrigerant oil may diminish performance and abnormal refrigerant cycles may be caused by the incompatibility of those oils.

WARNING

Do not operate air conditioning units charged with incorrect (or mixed) refrigerant (R22, R410A, R32). This may cause malfunction of the units, and at the same time, may cause a serious incident such as rupture of the refrigerant circuit.

Refilling refrigerant in service

When refilling is needed, follow this procedure to ensure the circuit is charged with the the correct amount of new refrigerant.

1. Attach a charging hose (blue) to the service port on the outdoor unit.
2. Attach a charging hose (red) to the vacuum pump. Fully open the two-way and three-way valves.
3. Place the refrigerant cylinder on the digital scale for refrigerant charging and connect the charge hose (yellow) to the connection port of the vacuum pump and the digital scale. Leave the cylinder valve fully open.
4. Fully open the Lo and Hi handles on the manifold gauge, and turn on the vacuum pump. Then perform evacuation for at least one hour or more.
5. Confirm the compound gauge reaches -30 inHg and fully open the Lo and Hi handles. Switch off the vacuum pump. Leave it for about 1 ~ 2 minutes and confirm the needle on the compound gauge does not move back. Refer to Figure 10-12.
6. Remove the charging hose (red) on the manifold gauge from the vacuum pump adapter.
7. After adjusting the digital scale to zero, open the cylinder valve and Lo valve on the manifold gauge, and add the refrigerant.
8. If it is not possible to add the regulated amount of refrigerant at once, operate the Cooling Mode and gradually add the refrigerant (recommended amount approx. 5.3 oz at a time).

*Do not add too much refrigerant all at once.

10 Servicing Centrus using R32

9. Close the open/close valve and add the refrigerant in the charging hose to the outdoor unit.
*Perform this procedure during cooling operation. Close the stem of the two-way valve, and when the pressure on the manifold gauge reads zero (0), quickly remove the charging hose (blue). Immediately open the two-way valve and stop the cooling operation.
10. Confirm that the two-way and three-way valves are fully open. Attach the caps of the service port and control valve, and then check for gas leakage around the caps.

Figure 10-13 Refilling refrigerant

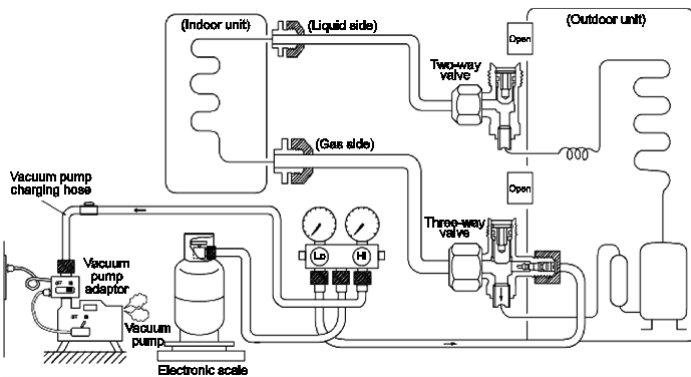

Analysis method for no error code, no cooling / no warming

In order to obtain appropriate operating characteristics, at least 15 minutes or more of operating time [test operation (rated operation)] is required.

Method of rated operation

For the models that have two buttons for “emergency operation” and “forced cooling operation,” press the forced cooling button once. For the models that have only an emergency operation button, press and hold the button once for 5 seconds and when you hear the beep, release the button. The cooling operation will start.

Checking the malfunctions of indoor / outdoor units

1. Are there any obstacles blocking heat release or air intake? (Short circuit, the outdoor unit cover has not been removed, or fallen leaves are blocking the outdoor unit)
2. Are the indoor unit air filters clean? (obstructing heat intake)
3. Is the temperature setting on the control pad correct? (is the temperature set lower/higher than the room temperature?)

Figure 10-14 Analysis for no error

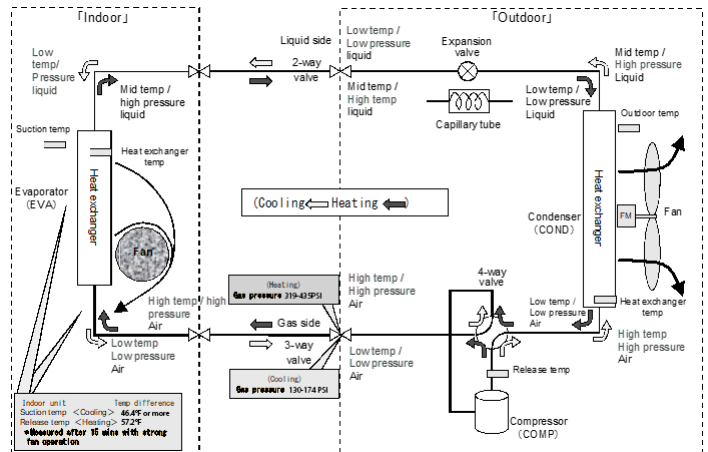

10 Servicing Centrus using R32

Measuring temperature

1. Indoor unit intake temperature, release temperature, temperature difference, → Measure with thermometer
2. Two-way valve pipe temperature in Cooling Mode is low (benchmark: 41 ~ 50°F), in Heating Mode is medium temperature (benchmark: 77 ~ 95°F).
3. Three-way valve pipe temperature in Cooling Mode is low (benchmark: 44.6 ~ 59°F) in Heating Mode is high (benchmark: 100.4 ~ 122°F).

Measuring electric current

Measuring electric current in operation → check by clamp meter (refer to table of technical characteristics guideline)

Measuring pressure

Measuring gas pressure → check the pressure on the manifold gauge (refer to table of technical characteristics guideline)

Any sound from the expansion valve? (When starting operation and the outdoor unit is turned on, the expansion valve is reset, check if there is any sharp sound or clicking sound.)

Table 10-11 Diagnosis of refrigeration cycle

COMPARISON WITH NORMAL OPERATION	COOLING MODE	
	HIGH	LOW
REFRIGERANT PRESSURE	Overfilling refrigerant	Clogged capillary, expansion valve malfunction
	Heat-releasing obstruction	Clog due to moisture
	Dirty condenser, adhesion of impurities	Lack of refrigerant gas
	Compressor malfunction	
OPERATION ELECTRIC CURRENT	Overfilling refrigerant	Lack of refrigerant gas
	Heat-releasing obstruction	Compressor malfunction
	Dirty condenser, impurities	Mixture of air
		(Insufficient evacuation)
TWO-WAY VALVE TEMPERATURE	Overfilling refrigerant	Clogged capillary, expansion valve malfunction
	Compressor malfunction	Lack of refrigerant gas
THREE-WAY VALVE TEMPERATURE	Lack of refrigerant gas • Compressor malfunction	Overfilling refrigerant
	Clogged capillary, expansion valve malfunction	
SUCTION TEMPERATURE & RELEASE AIR TEMPERATURE	TEMPERATURE DIFFERENCE AT OR LESS THAN 46.4°F IN COOLING OPERATION CAUSES	
	• Heat-releasing obstruction • Dirty condenser • Adhesion of impurities	
	• Lack of refrigerant gas • Overfilling of refrigerant	
	• Mixture of air • Mixture of moisture	
	• Clogged capillary • Expansion valve malfunction • Compressor malfunction	

All of the information above is based on the condition that the installation work is properly performed (no issues in indoor / outdoor pipe connections, etc.)



*Revision Notes: (PCP #3000066159 / CN #500051740) initial release.
Revision B (PCP #3000070431 / CN #500055911) reflects updates throughout.*

100391918_2000846611_Rev B
03/26